

Features

- 2-way normally open operation
- For control of commercial and industrial gas burners
- Ideal for low pressure applications
- Brass body construction
- Mountable in any position

Fluid

Fuel Gas

Construction

Valve Parts in Contact with Fluids	
Body	Brass
Seals and Disc	NBR
Core Tube	305 Stainless Steel
Stem	PA
Core and Plugnut	430F Stainless Steel
Springs	302 Stainless Steel
Shading Coil	Copper

Electrical

Standard Oil and Class of Insulation	Watt Rating and Power Consumption			Ambient Temp. °F	Spare Coil Family	
	AC				General Purpose	Explosionproof
	Watts	VA Holding	VA Inrush		AC	AC
F	10.1	25	70	32 to 125	238610	238614
H	10.1	25	70	32 to 140	272810	-
F	16.1	27	160	32 to 125	272610	272614
H	16.1	27	160	32 to 140	238810	238814

Standard Voltages: 24, 120, 240 volts AC, 60 Hz (or 110, 220 volts AC, 50 Hz).
Optional High Ambient Temp: 140°F Class H coil with prefix HT.

Solenoid Enclosures

Standard: Watertight, Types 1, 2, 3, 3S, 4, and 4X with 1/2" conduit hub.

Optional: RedHat II - Explosionproof and Watertight. To order, add Prefix "EF" to catalog numbers. (e.g. EF8030G082)

Valve Response Time

Opening Time: Less than 1 second

Closing Time: Less than 1 second

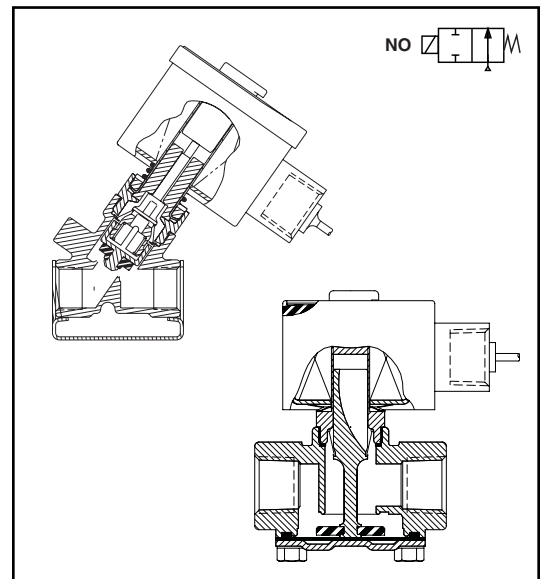
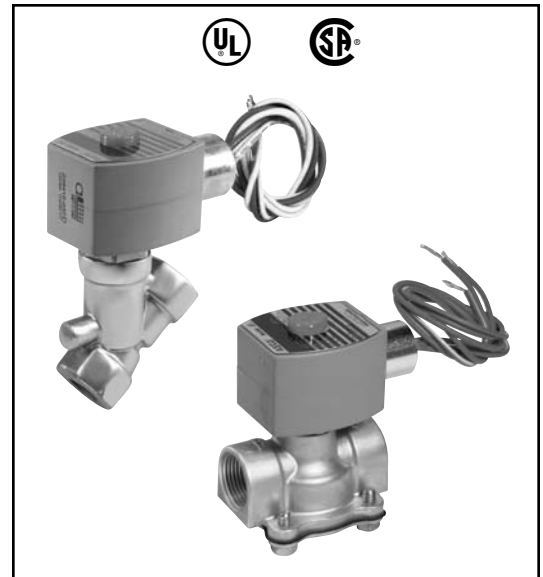

Approvals

UL listed to standard 429 "Electrically Operated Valves," Guide Y10Z, File MP618, General Purpose Valves.

CSA Certified to:
 Standard C22.2 No. 139 "Electrically Operated Valves,"
 File 010381.

COMBUSTION

Specifications (English units)

Pipe Size (ins.)	Orifice Size (ins.)	Cv Flow Factor	Gas Capacity ① Btu/hr.	Operating Pressure Differential (psi)		Max. Fluid Temp. °F	Catalog Number	Const. Ref.	Agency			Wattage	Approx. Shipping Weight (lbs)
				Min.	Max.				UL	FM	CSA		
COMBUSTION (Fuel Gas) - NORMALLY OPEN													
3/8	3/8	1.6	86,000	0	15	200	8030G070	1	●	-	●	16.1	3.4
1/2	3/4	5.0	269,000	0	2	180	8030G082	2	●	-	●	10.1	3.4
3/4	3/4	5.5	295,000	0	2	180	8030G083	3	●	-	●	10.1	3.4

● = General Purpose Valve. ① 1" W.C. Drop @ 2" W.C. Inlet Pressure, 1,000 Btu/Cu.Ft. or more, 0.64 Specific Gravity Gas.

Specifications (Metric units)

Pipe Size (ins.)	Orifice Size (mm)	Kv Flow (m³/hr)	Gas Capacity ① Btu/hr.	Operating Pressure Differential (bar)		Max. Fluid Temp. °C	Catalog Number	Const. Ref.	Agency			Wattage	Approx. Shipping Weight (kgs)
				Min.	Max.				UL	FM	CSA		
COMBUSTION (Fuel Gas) - NORMALLY OPEN													
3/8	10	1.4	86,000	0	1.0	93	8030G070	1	●	-	●	16.1	1.5
1/2	19	4.3	269,000	0	0.1	82	8030G082	2	●	-	●	10.1	1.5
3/4	19	4.7	295,000	0	0.1	82	8030G083	3	●	-	●	10.1	1.5

● = General Purpose Valve. ① 1" W.C. Drop @ 2" W.C. Inlet Pressure, 1,000 Btu/Cu.Ft. or more, 0.64 Specific Gravity Gas.

Capabilities Chart

Solenoid Options				Base Catalog Number	Resilient Materials	Standard Rebuild Kit
NEMA Type 3-9	High Temp.	Junction Box	Wiring Box Screw Terminal	Brass	NBR	AC
EF	HT	JB	JKF	8030G070	●	302797
EF	HT	JB	JKF	8030G082	●	302799
EF	HT	JB	JKF	8030G083	●	302799

● = Standard. Other options may be available. All option combinations may not be available.

Dimensions inches (mm)

Const. Ref.	H	K	L	P	W
1	ins. 4.16	1.10	1.91	3.72	2.06
	mm 106	28	49	94	52
2	ins. 3.97	1.88	2.81	2.85	2.29
	mm 101	48	71	72	58
3	ins. 3.97	1.88	2.81	2.85	2.29
	mm 101	48	71	72	58

Vent Valve Requirements

Manifold Line	Vent Valve
3/8" through 1 1/2"	3/4
2"	1
2 1/2" through 3"	1 1/4
3 1/2"	1 1/2
4" through 5"	2
5 1/2" through 6"	2 1/2
6 1/2" through 7 1/2"	3

COMBUSTION