

Features

- Corrosion-resistant plastic bodies
- Available with compression fitting ends for metal or plastic tube to save installation cost
- Mountable in any position
- Dispensing vending construction NSF listed

Construction

Valve Parts in Contact with Fluids	
Body	CA, PA, PP
Seals and Disc	NBR
Core Tube	305 Stainless Steel
Core and Plugnut	430F Stainless Steel
Springs	302 Stainless Steel
Shading Coil	Copper

Electrical

Standard Coil and Class of Insulation	Watt Rating and Power Consumption				Spare Coil Part Number	
	DC Watts	Watts	AC		General Purpose	
			VA Holding	VA Inrush	AC	DC
B	6.4	6.5	9.2	17.3	174879	180555
F	10.6	6.1	16	30	238210	238310

Standard Voltages: 24, 120, 240, 480 volts AC, 60 Hz (or 110, 220 volts AC, 50 Hz).
 6, 12, 24, 120, 240 volts DC. Must be specified when ordering.
 Other voltages available when required.

Solenoid Enclosures

Standard: Watertight, Types 1, 2, 3, 3S, 4, and 4X.

Optional: Open Frame Solenoid, Junction Box enclosures.

See *Optional Features Section* for descriptions on these options.

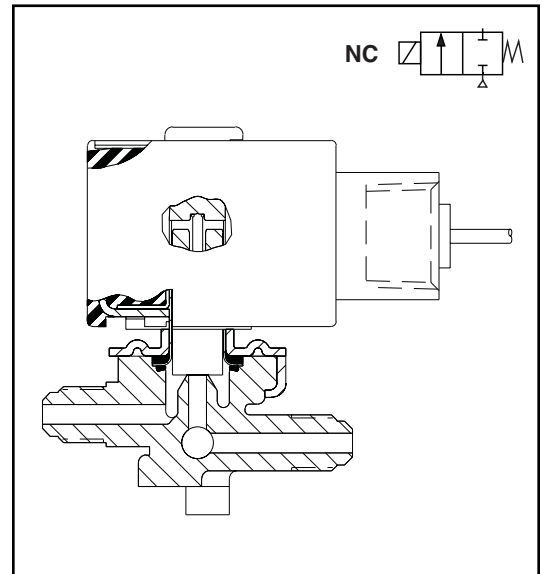

Nominal Ambient Temp. Range:

AC: 32°F to 125°F (0°C to 52°C)

DC: 32°F to 104°F (0°C to 40°C)

Refer to *Engineering Section* for details.

Approvals:

CSA certified. UL Recognized Component. Meets applicable CE directives.

Refer to *Engineering Section* for details.

Specifications (English units)

Pipe Connections	Orifice Size (ins.)	Cv Flow Factor	Operating Pressure Differential (psi)				Max. Fluid Temp. °F		Plastic Body		Watt Rating/ Class of Coil Insulation ②	
			Max. AC		Max. DC		AC	DC	Catalog Number	Const. Ref.	AC	DC
			Air-Inert Gas	Water	Air-Inert Gas	Water						
GENERAL SERVICE CONSTRUCTION - CA Body, Watertight enclosure with leads												
1/4" Male Flare	9/64	.35	120	120	50	50	130	120	8260G042	1	6.1/F	10.6/F
Bib for 1/4" I.D. Tube	9/64	.35	120	120	50	50	130	120	8260G054	2	6.1/F	10.6/F
1/4" O.D. ① Compression	9/64	.35	120	120	50	50	130	120	8260G071	3	6.1/F	10.6/F
GENERAL SERVICE CONSTRUCTION - PP Body, Open Frame Solenoid and Spade Terminal Coils												
1/4" O.D. ① Compression	1/16	.09	150	150	60	60	130	120	USM8260 073	5	6.5/B	6.4/B
	3/32	.19	100	100	20	20	130	120	USM8260 074	5	6.5/B	6.4/B
	1/8	.31	60	60	10	10	130	120	USM8260 075	5	6.5/B	6.4/B
	5/32	.43	35	35	5	5	130	120	USM8260 076	5	6.5/B	6.4/B
DISPENSING VENDING CONSTRUCTION - NSF Listed - PP Body, Open Frame Solenoid and Spade Terminal Coils												
1/4" O.D. ① Compression	1/16	.09	150	150	60	60	130	120	USM8260 077	4	6.5/B	6.4/B
	3/32	.19	100	100	20	20	130	120	USM8260 078	4	6.5/B	6.4/B
	1/8	.31	60	60	10	10	130	120	USM8260 079	4	6.5/B	6.4/B
	5/32	.43	35	35	5	5	130	120	USM8260 080	4	6.5/B	6.4/B
PA Body, Open Frame Solenoid and Spade Terminal Coils												
3/8" O.D. ① Compression	5/16	1.3	5	5	-	-	130	-	USM8260 089	6	6.5/B	-

① Fittings not supplied with valve. To order, refer to Kit No. 224150 - plastic tubing, and Kit No. 224151 - metal tubing.
② On 50 hertz service, the watt rating for the 6.1/F solenoid is 8.1 watts.

Specifications (Metric units)

Pipe Connections	Orifice Size (mm)	Kv Flow Factor (m3/h)	Operating Pressure Differential (bar)				Max. Fluid Temp. °C		Plastic Body		Watt Rating/ Class of Coil Insulation ②	
			Max. AC		Max. DC		AC	DC	Catalog Number	Const. Ref.	AC	DC
			Air-Inert Gas	Water	Air-Inert Gas	Water						
GENERAL SERVICE CONSTRUCTION - CA Body, Watertight enclosure with leads												
1/4" Male Flare	3.6	.30	8.3	8.3	3.4	3.4	54	49	8260G042	1	6.1/F	10.6/F
Bib for 1/4" I.D. Tube	3.6	.30	8.3	8.3	3.4	3.4	54	49	8260G054	2	6.1/F	10.6/F
1/4" O.D. ① Compression	3.6	.30	8.3	8.3	3.4	3.4	54	49	8260G071	3	6.1/F	10.6/F
GENERAL SERVICE CONSTRUCTION - PP Body, Open Frame Solenoid and Spade Terminal Coils												
1/4" O.D. ① Compression	1.6	.08	10.3	10.3	4.1	4.1	54	49	USM8260 073	5	6.5/B	6.4/B
	2.4	.16	6.9	6.9	1.4	1.4	54	49	USM8260 074	5	6.5/B	6.4/B
	3.2	.27	4.1	4.1	0.7	0.7	54	49	USM8260 075	5	6.5/B	6.4/B
	4.0	.37	2.4	2.4	0.3	0.3	54	49	USM8260 076	5	6.5/B	6.4/B
DISPENSING VENDING CONSTRUCTION - NSF Listed - PP Body, Open Frame Solenoid and Spade Terminal Coils												
1/4" O.D. ① Compression	1.6	.08	10.3	10.3	4.1	4.1	54	49	USM8260 077	4	6.5/B	6.4/B
	2.4	.16	6.9	6.9	1.4	1.4	54	49	USM8260 078	4	6.5/B	6.4/B
	3.2	.27	4.1	4.1	0.7	0.7	54	49	USM8260 079	4	6.5/B	6.4/B
	4.0	.37	2.4	2.4	0.3	0.3	54	49	USM8260 080	4	6.5/B	6.4/B
PA Body, Open Frame Solenoid and Spade Terminal Coils												
3/8" O.D. ① Compression	7.9	1.11	0.3	0.3	-	-	54	-	USM8260 089	6	6.5/B	-

① Fittings not supplied with valve. To order, refer to Kit No. 224150 - plastic tubing, and Kit No. 224151 - metal tubing.
② On 50 hertz service, the watt rating for the 6.1/F solenoid is 8.1 watts.

Dimensions: inches (mm)

Const. Ref. 1

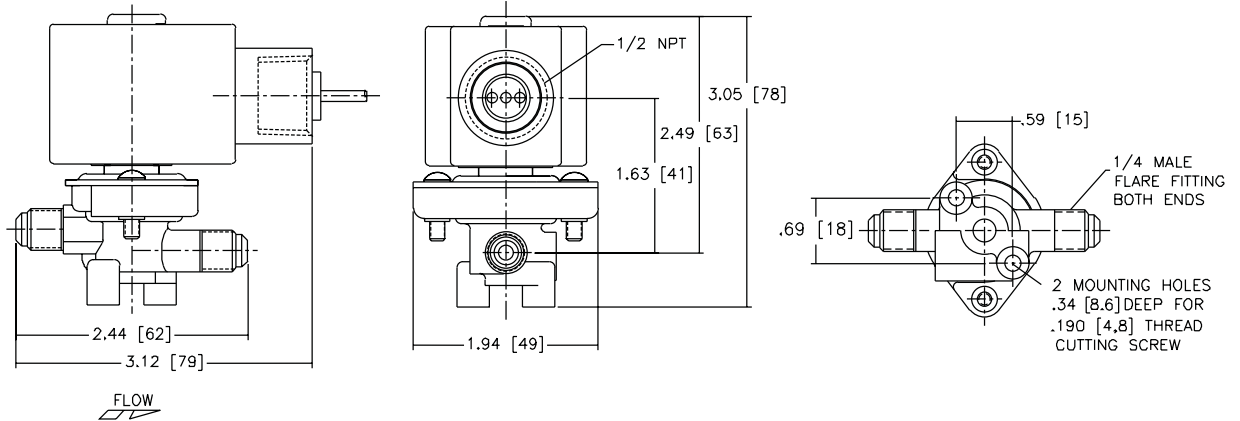

Const. Ref. 2

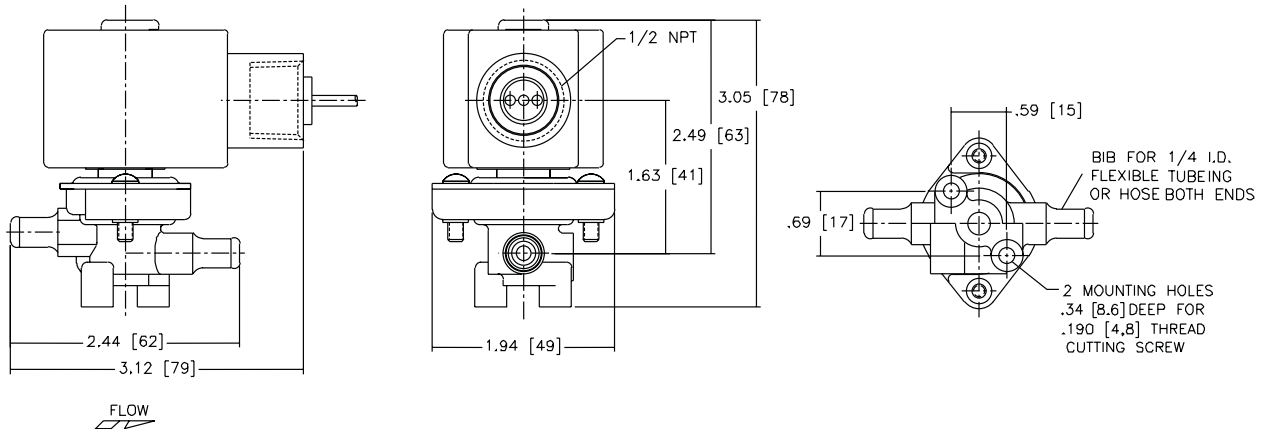

Const. Ref. 3

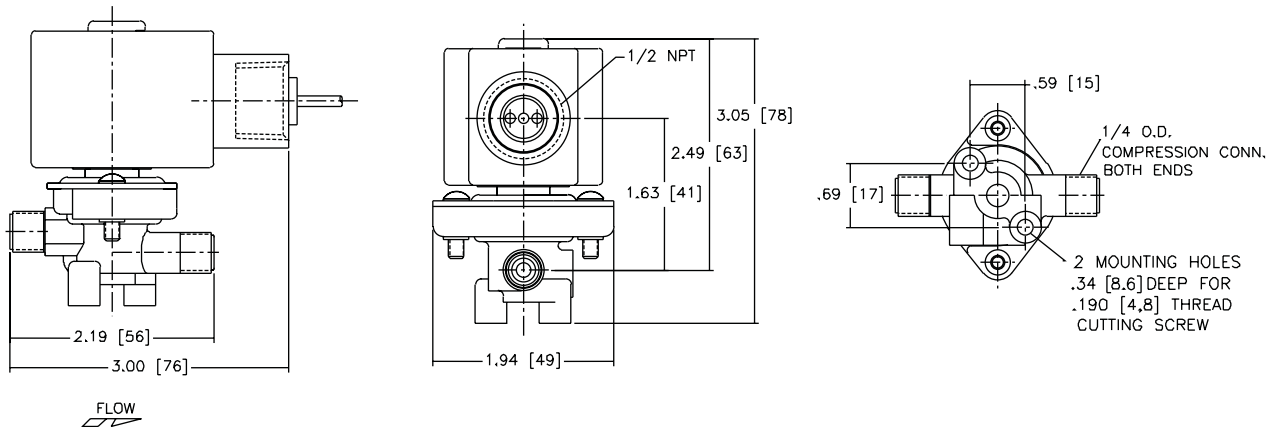

Dimensions: inches (mm)

Const. Ref. 4

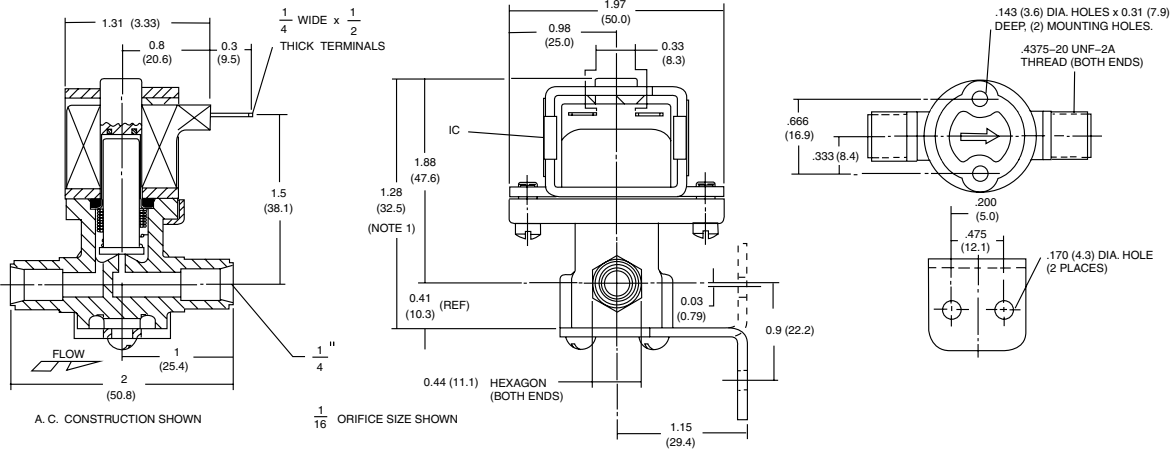

Const. Ref. 5

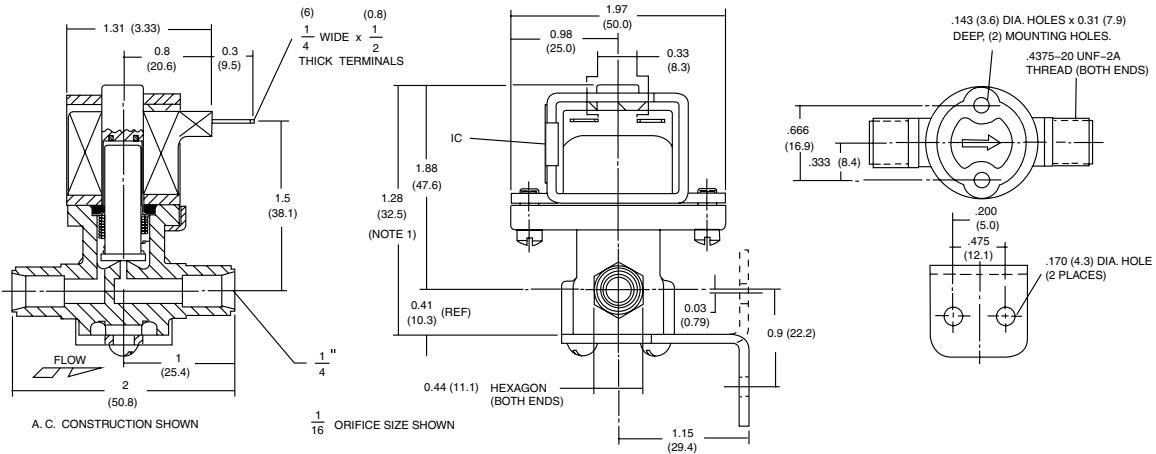

Const. Ref. 6

