

Features

- 2-way normally closed operation
- For gas pilot control of commercial and industrial gas burners
- Direct lift with resilient soft seating for tight shutoff
- Brass body construction
- Mountable in any position

Fluid

Fuel Gas

Construction

Valve Parts in Contact with Fluids	
Body	Brass
Seals and Disc	LT NBR
Core Tube	305 Stainless Steel
Core Guide	Acetal
Rider Ring	PTFE
Core and Plugnut	430F Stainless Steel
Springs	Inconel 600
Shading Coil	Copper

Electrical

Standard Coil and Class of Insulation	Watt Rating and Power Consumption			Ambient Temp. °F	Spare Coil Family	
	AC				General Purpose	Explosionproof
	Watts	VA Holding	VA Inrush		AC	AC
F	10.1	25	70	-40 to 131	238610	238614
H	10.1	25	70	-40 to 140	238810	238814

Standard Voltages: 24, 120, 240 volts AC, 60 Hz (or 110, 220 volts AC, 50 Hz).
Optional High Ambient Temp: 140°F Class H coil with prefix HT.

Solenoid Enclosures

Standard: Watertight; Types 1, 2, 3, 3S, 4, and 4X with 1/2" conduit hub.

Optional: RedHat II - Explosionproof and Watertight, Types 3, 3S, 4, 4X, 6, 6P, 7, and 9; RedHat - Explosionproof and Raintight, Types 3, 7, and 9.
 (To order, add prefix "EF" to catalog number.)

Valve Response Time

Opening Time: Less than 1 second

Closing Time: Less than 1 second

Options

High Ambient 140°F (prefix HT)

Din Connector (prefix SC for standard, prefix SU for high temperature)

Mounting Bracket (suffix MB)

Silicone Free Service (suffix SF)

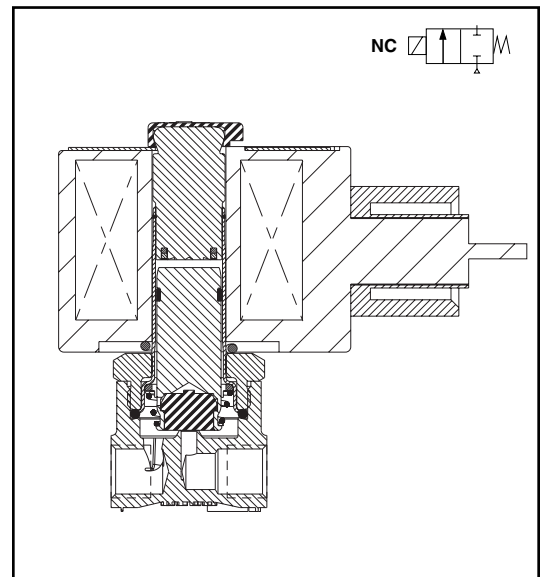

Approvals

UL listed to standard 429 "Electrically Operated Valves," Guide Y10Z, File MP618 Safety Shutoff Valves.

FM Approved to Class 7400 "Liquid and Gas Safety Shutoff Valves."

CSA Certified to:

- 1) Standard C22.2 No. 139 "Electrically Operated Valves," File 010381.
- 2) Automatic Gas Valves Z21.21 (6.5), File 112872.
- 3) Automatic Gas Safety Shutoff Valves C/I (3.9), File 112872.

Specifications (English units)

Pipe Size (ins.)	Orifice Size (ins.)	Cv Flow Factor	Gas Capacity ① Btu/hr.	Operating Pressure Differential (psi)		Max. Fluid Temp. °F	Catalog Number	Const. Ref.	Agency			Wattage	Approx. Shipping Weight (lbs)
				Min.	Max.				UL	FM	CSA		
COMBUSTION (Fuel Gas) - NORMALLY CLOSED (Closed when de-energized)													
1/8	1/8	.35	18,700	0	200	125	8262H077	1	○	○	○	10.1	1.2
1/4	9/32	1.0	53,500	0	50	125	8262H078	2	○	○	○	10.1	1.3

○ = Safety Shutoff Valve. ① 1" W.C. Drop @ 2" W.C. Inlet Pressure, 1,000 Btu/cu.ft. or more, 0.64 Specific Gravity Gas.

Specifications (Metric units)

Pipe Size (ins.)	Orifice Size (mm)	Kv Flow (m³/hr)	Gas Capacity ① Btu/hr.	Operating Pressure Differential (bar)		Max. Fluid Temp. °C	Catalog Number	Const. Ref.	Agency			Wattage	Approx. Shipping Weight (kgs)
				Min.	Max.				UL	FM	CSA		
COMBUSTION (Fuel Gas) - NORMALLY CLOSED (Closed when de-energized)													
1/8	3	0.30	15,000	0	13.8	52	8262H077	1	○	○	○	10.1	0.5
1/4	7	0.87	51,700	0	3.4	52	8262H078	2	○	○	○	10.1	0.6

○ = Safety Shutoff Valve. ① 1" W.C. Drop @ 2" W.C. Inlet Pressure, 1,000 Btu/cu.ft. or more, 0.64 Specific Gravity Gas.

Capabilities Chart

Solenoid Options				Base Catalog Number	Resilient Materials	Standard Rebuild Kit
NEMA Type 3-9	High Temp.	Screw Terminal Wiring Box	Spade Wiring Box	Brass	LT NBR	AC
EF	HT	JKF	JSF	8262H077	●	325039
EF	HT	JKF	JSF	8262H078	●	325039

● = Standard. Other options may be available. All option combinations may not be available.

Dimensions inches (mm)

Const. Ref.		H	K	L	P	W
1	ins	3.05	1.71	1.19	2.69	1.95
	mm	77	43	30	68	50
2	ins	3.12	1.79	1.56	2.76	1.95
	mm	79	45	40	70	50

Const. Ref. 1, 2

Const. Ref. 1

*ACCEPTS STANDARD #10-32 MACHINE SCREW

Const. Ref. 2