

Features

- NAMUR direct mount construction
- Balanced Poppet construction provides high flow with low power consumption
- PTFE rider rings and graphite-filled PTFE seals reduce friction and eliminate sticking for long life
- No minimum pressure required
- Tamperproof no-voltage release manual reset provides added safety

Construction

Valve Parts in Contact with Fluids		
Body	Aluminum	316 Stainless Steel
Seals and Discs	VMQ	
	NBR	FKM
Core Tube	305 Stainless Steel	
Stem and Insert	303 Stainless Steel	
Core and Plugnut	430F Stainless Steel	
Springs	302 Stainless Steel	
Rider Rings	PTFE	

Electrical

Standard Coil and Class of Insulation	Watt Rating and Power Consumption				Spare Coil Part Number			
	DC Watts	AC			General Purpose		Explosionproof	
		Watts	VA Holding	VA Inrush	AC	DC	AC	DC
F	11.6	12	24	24	276000	238710	276002	238714

Standard Voltages: 24, 120, 240, 480 volts AC, 60 Hz. 6, 12, 24, 120, 240 volts DC.
 Must be specified when ordering. Other voltages are available when required.

Solenoid Enclosures

Standard: Watertight, Types 1, 2, 3, 3S, 4, and 4X.

Optional: Explosionproof and Watertight, Types 3, 3S, 4, 4X, 6, 6P, 7, and 9.
 (To order, add prefix "EF" or, for Explosionproof Stainless Steel trim and hub on Aluminum-Bodied valves, add "EV" to catalog number.)

See *Optional Features Section* for other available options.

SIL (Safety Integrity Level) Information:

- PFD (Probability of Failure on Demand) < 4 x 10⁻⁷ at a confidence factor of 95%.
- SFF (Safe Failure Fraction) according to IEC 61508-2 Table A1 is ≥ 0.99.
- Only constructions without manual operators apply to the above criteria.

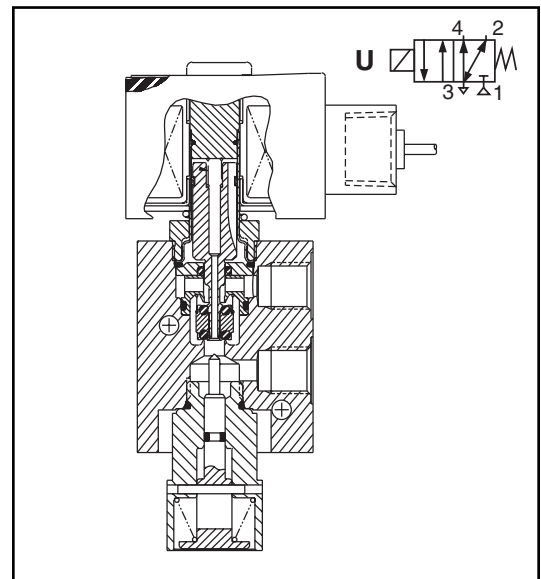
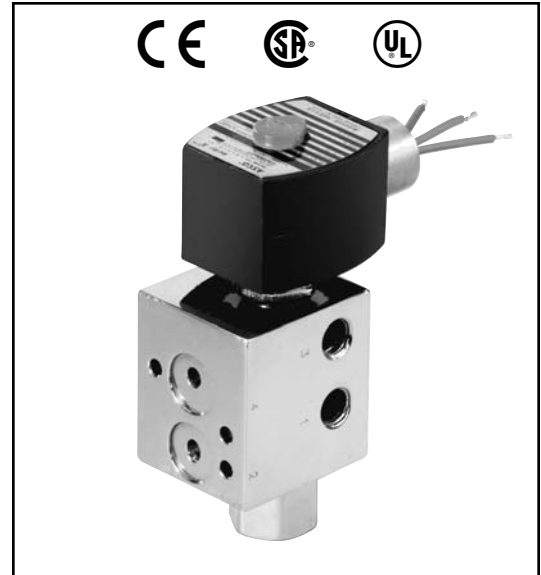

VALVE AUTOMATION

Nominal Ambient Temp. Ranges

8327G033 and 35: -4°F to 131°F (-20°C to 55°C)
 8327G053 and 55: -40°F to 131°F (-40°C to 55°C)
 Refer to *Engineering Section* for details.

Approvals

General Purpose Solenoid:

UL recognized component, CSA certified.

Explosionproof Solenoid: (Prefix EF and EV)

UL listed solenoid.

CSA certified for use in hazardous Locations.

Meets applicable CE directives.

Refer to *Engineering Section* for details.

Specifications (English units)

Pipe Size (ins.)	Orifice Size (ins.)	Cv Flow Factor		Maximum Operating Pressure Diff. (psi) Air-Inert Gas	Fluid Temp. Range °F	Aluminum Body	Stainless Steel Body	Const. Ref.	Watt Rating/ Class of Coil Insulation	
		Ports 1-2	Ports 2-3			Catalog Number	Catalog Number		AC	DC
UNIVERSAL - Low-Temperature Operation										
1/4	1/4	.52	.53	150	-40 to 131	8327G053	EV8327G055	1	12.0/F	11.6/F
UNIVERSAL MANUAL RESET - Tamperproof No-Voltage Release										
1/4	1/4	.62	.43	150	-4 to 176	8327G033	-	2	12.0/F	11.6/F
1/4	1/4	.62	.43	150	-4 to 248	-	EV8327G035	2	12.0/F	11.6/F

Specifications (Metric units)

Pipe Size (ins.)	Orifice Size (mm)	Kv Flow Factor (m3/h)		Maximum Operating Pressure Diff. (bar) Air-Inert Gas	Fluid Temp. Range °C	Aluminum Body	Stainless Steel Body	Const. Ref.	Watt Rating/ Class of Coil Insulation	
		Ports 1-2	Ports 2-3			Catalog Number	Catalog Number		AC	DC
UNIVERSAL - Low-Temperature Operation										
1/4	6.4	.45	.45	10	-40 to 55	8327G053	EV8327G055	1	12.0/F	11.6/F
UNIVERSAL MANUAL RESET - Tamperproof No-Voltage Release										
1/4	6.4	.53	.37	10	-20 to 80	8327G033	-	2	12.0/F	11.6/F
1/4	6.4	.53	.37	10	-20 to 120	-	EV8327G035	2	12.0/F	11.6/F

VALVE
AUTOMATION

Dimensions inches (mm)

