

Features

- Designed for high-flow piloting with no minimum operating pressure required; e.g. power plants, refineries, chemical processing
- Balanced poppet construction for high flow at minimum power levels
- PTFE rider rings and graphite-filled seals reduce friction and eliminate sticking to provide exceptional service life
- 316 Stainless Steel construction for highly corrosive atmospheres

Construction

Valve Parts in Contact with Fluids		
Body	Brass	316 Stainless Steel
Core Tube	305 Stainless Steel	
Stem and Insert	303 Stainless Steel	
Core and Plugnut	430F Stainless Steel	
O-Ring Holder	430F Stainless Steel	
Springs	302 Stainless Steel	
Seals and Discs	NBR	FKM
Rider Ring	PTFE	

Electrical

Standard Coil and Class of Insulation	Watt Rating and Power Consumption				Spare Coil Part Number			
	DC Watts	AC			General Purpose		Explosionproof	
		Watts	VA Holding	VA Inrush	AC	DC	AC	DC
F	11.6	12.0	12	12	276000	238710	276002	238714

Standard Voltages: 24/50-60, 120/50-60, 240/50-60, and 480/50-60 volts AC, or 6, 12, 24, 120 and 240 volts DC.

Solenoid Enclosures

Standard: Brass valves: Types 1, 2, 3, 3S, 4, and 4X.

316 Stainless Steel valves: Explosionproof and Watertight Types 3, 3S, 4, 4X, 6, and 6P.

Optional: Explosionproof and Watertight, Types 3, 3S, 4, 4X, 6, 6P, 7, and 9. (To order, add prefix "EF" to catalog number. For explosionproof with 316 Stainless Steel hub and trim, specify prefix "EV".)

See *Optional Features Section* for other available options.

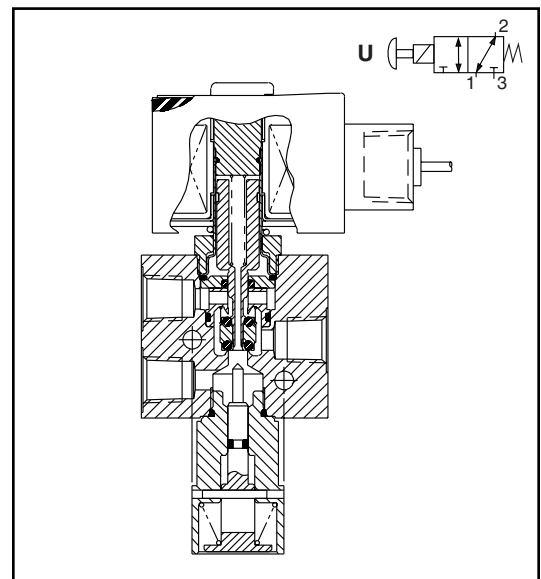
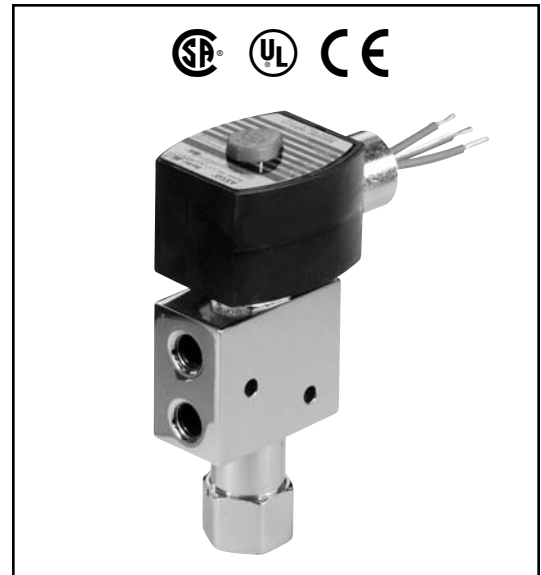

SPECIAL SERVICE PILOT

Nominal Ambient Temp. Ranges

-4°F to 131°F (-20°C to 55°C)

Refer to *Engineering Section* for details.

Approvals

CSA certified. UL listed General Purpose Valves. Meets applicable CE directives.

Refer to *Engineering Section* for details.

Operation Alternatives

No Voltage Release - valves must be manually moved to the "open" latched position with the solenoid energized.

Tamperproof No Voltage Release - valves operate as above, but cannot be held open manually with solenoid de-energized.

Specifications (English units)

Pipe Size (ins.)	Orifice Size (ins.)	Cv Flow Factor		Maximum Operating Pressure Differential (psi)			Max. Fluid Temp. °F	316 Stainless Steel Body		Const. Ref.	Watt Rating/ Class of Coil Insulation	
		Ports 1-2	Ports 2-3	Air-Inert Gas	Water	Light Oil @ 300 SSU		Brass Body Catalog Number	316 Stainless Steel Body Catalog Number		AC	DC
UNIVERSAL MANUAL RESET- No Voltage Release												
1/4	1/4	.60	.73	150	150	150	176	8327G021	-	1	12.0/F	11.6/F
1/4	1/4	.60	.73	150	150	150	248	-	EV8327G022	1	12.0/F	11.6/F
UNIVERSAL MANUAL RESET- Tamperproof No Voltage Release												
1/4	1/4	.60	.73	150	150	150	176	8327G031	-	1	12.0/F	11.6/F
1/4	1/4	.60	.73	150	150	150	248	-	EV8327G032	1	12.0/F	11.6/F

Specifications (Metric units)

Pipe Size (ins.)	Orifice Size (mm)	Kv Flow Factor (m3/h)		Maximum Operating Pressure Differential (bar)			Max. Fluid Temp. °C	316 Stainless Steel Body		Const. Ref.	Watt Rating/ Class of Coil Insulation	
		Ports 1-2	Ports 2-3	Air-Inert Gas	Water	Light Oil @ 300 SSU		Brass Body Catalog Number	316 Stainless Steel Body Catalog Number		AC	DC
UNIVERSAL MANUAL RESET- No Voltage Release												
1/4	6	.51	.63	10	10	10	80	8327G021	-	1	12.0/F	11.6/F
1/4	6	.51	.63	10	10	10	120	-	EV8327G022	1	12.0/F	11.6/F
UNIVERSAL MANUAL RESET- Tamperproof No Voltage Release												
1/4	6	.51	.63	10	10	10	80	8327G031	-	1	12.0/F	11.6/F
1/4	6	.51	.63	10	10	10	120	-	EV8327G032	1	12.0/F	11.6/F

Dimensions: inches (mm)

FLOW DIAGRAMS

OPERATION	DE-ENERGIZED	ENERGIZED
NORMALLY CLOSED PRESSURE AT 3		
NORMALLY OPEN PRESSURE AT 1		
UNIVERSAL PRESSURE AT ANY PORT		

Const. Ref. 1

IMPORTANT: Valves may be mounted in any position.

SPECIAL SERVICE PILOT