

### Features

- Mount directly to actuators with NAMUR, Keystone, or Worcester interfaces
- Easy conversion from AC to DC by simply changing coil
- Standard momentary/maintained manual operator
- 3/2 is normally closed poppet design for spring return actuators
- 3/2 normally closed or 4/2 operation can be selected by rotating sub-base gasket
- 3/2 normally closed or 4/2 valves have built-in linear flow device capable of controlling Cv from 0.10 to 0.50
- Breather block exhausts to spring side of actuator to prevent corrosion of the actuator
- Unique CA slide and ceramic flow plate for extra-long life

### Construction

Valve Parts in Contact with Fluids	
Core Tube	305 Stainless Steel
Core and Plugnut	430F Stainless Steel
Springs	302 Stainless Steel
Seals	Low-Friction, Low-Wear NBR
Interface Plate	Molded PA
8401 Series Only	
Pressure Port	303 Stainless Steel
Main and Pilot Body	Molded PA
Spool	CA
Slide	Graphite-filled PTFE
Flow Plate	Ceramic (Alumina)
Worcester Version	
Main Body and Sub-Base	Anodized Aluminum

### Electrical

Standard Coil and Class of Insulation	Watt Rating and Power Consumption				Spare Coil Part Number	
	DC Watts	AC			AC	AC
		Watts	VA Holding	VA Inrush		
F	6.9	6.3	8.8	12.1	266763	270008

**Standard Voltages:** 24, 120, 240 volts AC, 60 Hz (or 110, 220 volts AC, 50 Hz).  
6, 12, 24, 120, 240 volts DC. Must be specified when ordering.  
Other voltages available upon request.

### Solenoid Enclosures

**Standard:** Watertight, Types 1, 2, 3, 3S, 4, and 4X.

**Optional:** Explosionproof and Watertight, Types 3, 3S, 4, 4X, 6, 6P, 7, and 9. (To order, change "WT" catalog number prefix to "EF".)

Molded epoxy coil per 3 x DIN 46244. (To order, change "WT" catalog number prefix to "SC".)

Molded epoxy open frame Class F coil with 18" leads. (To order, change "WT" catalog number prefix to "U".)

See *Optional Features Section* for other available options.

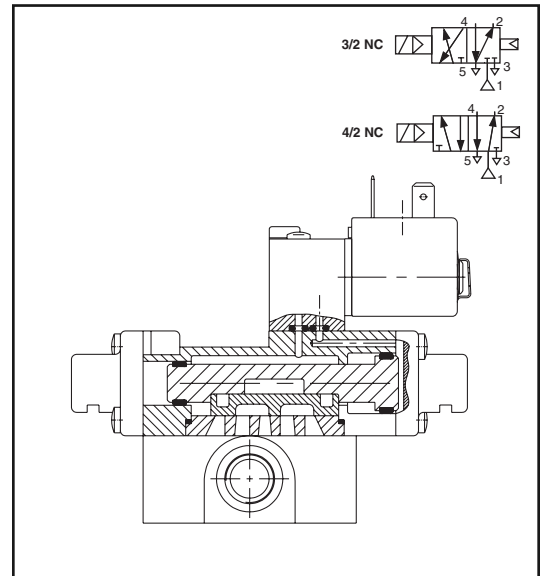
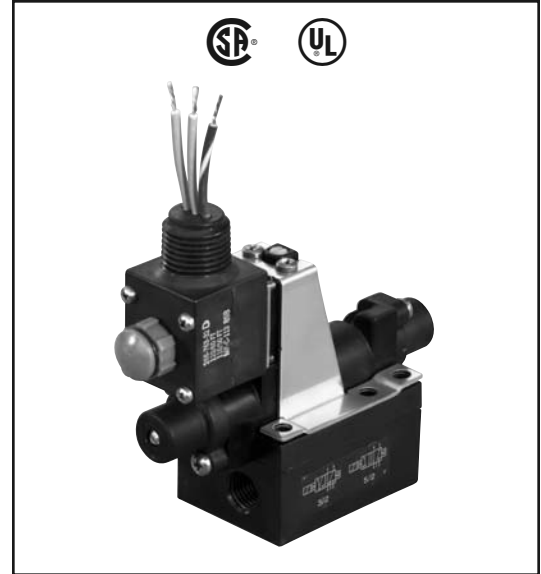

VALVE  
AUTOMATION

### Nominal Ambient Temp. Ranges

AC: 0°F to 104°F (-18°C to 40°C),  
except prefixes "U" and "SC" to 135°F (57°C)  
DC: 0°F to 77°F (-18°C to 25°C)

### Approvals

"WT" - UL recognized component General Purpose Valve, CSA certified.

"EF" - UL listed solenoid, CSA certified.

"U" and "SC" - UL recognized component, CSA certified.

Refer to *Engineering Section* for details.

**Specifications (English units)**

Pipe Size (ins.)	Orifice Size (ins.)	Cv Flow Factor	Main Line Supply Pressure (psi) AC and DC				Catalog Number	Const. Ref.	Interface Type	Watt Rating/ Class of Coil Insulation	
			Air-Inert Gas		Max. Fluid Temp. °F					AC	DC
			Min.	Max.	AC	DC					
<b>3-WAY NORMALLY CLOSED (Closed when de-energized)</b>											
1/4	3/64	.05	0	150	104	77	WT8380B202	1	NAMUR	6.3/F	6.9/F
<b>3-WAY NORMALLY CLOSED OR 4-WAY</b>											
1/4	1/4	.50	20	150	104	77	WT8401B202M	2	NAMUR	6.3/F	6.9/F
1/4	1/4	.50	20	150	104	77	WT8401B204M	2	Keystone	6.3/F	6.9/F
1/8	1/4	.40	20	135	104	77	WT8401B200M	3	Worcester	6.3/F	6.9/F

**Specifications (Metric units)**

Pipe Size (ins.)	Orifice Size (mm)	Kv Flow Factor (m3/h)	Main Line Supply Pressure (bar) AC and DC				Catalog Number	Const. Ref.	Interface Type	Watt Rating/ Class of Coil Insulation	
			Air-Inert Gas		Max. Fluid Temp. °C					AC	DC
			Min.	Max.	AC	DC					
<b>3-WAY NORMALLY CLOSED (Closed when de-energized)</b>											
1/4	1	.04	0	10	40	25	WT8380B202	1	NAMUR	6.3/F	6.9/F
<b>3-WAY NORMALLY CLOSED OR 4-WAY</b>											
1/4	6	.43	1	10	40	25	WT8401B202M	2	NAMUR	6.3/F	6.9/F
1/4	6	.43	1	10	40	25	WT8401B204M	2	Keystone	6.3/F	6.9/F
1/8	6	.34	1	9	40	25	WT8401B200M	3	Worcester	6.3/F	6.9/F

**Dimensions inches (mm)**

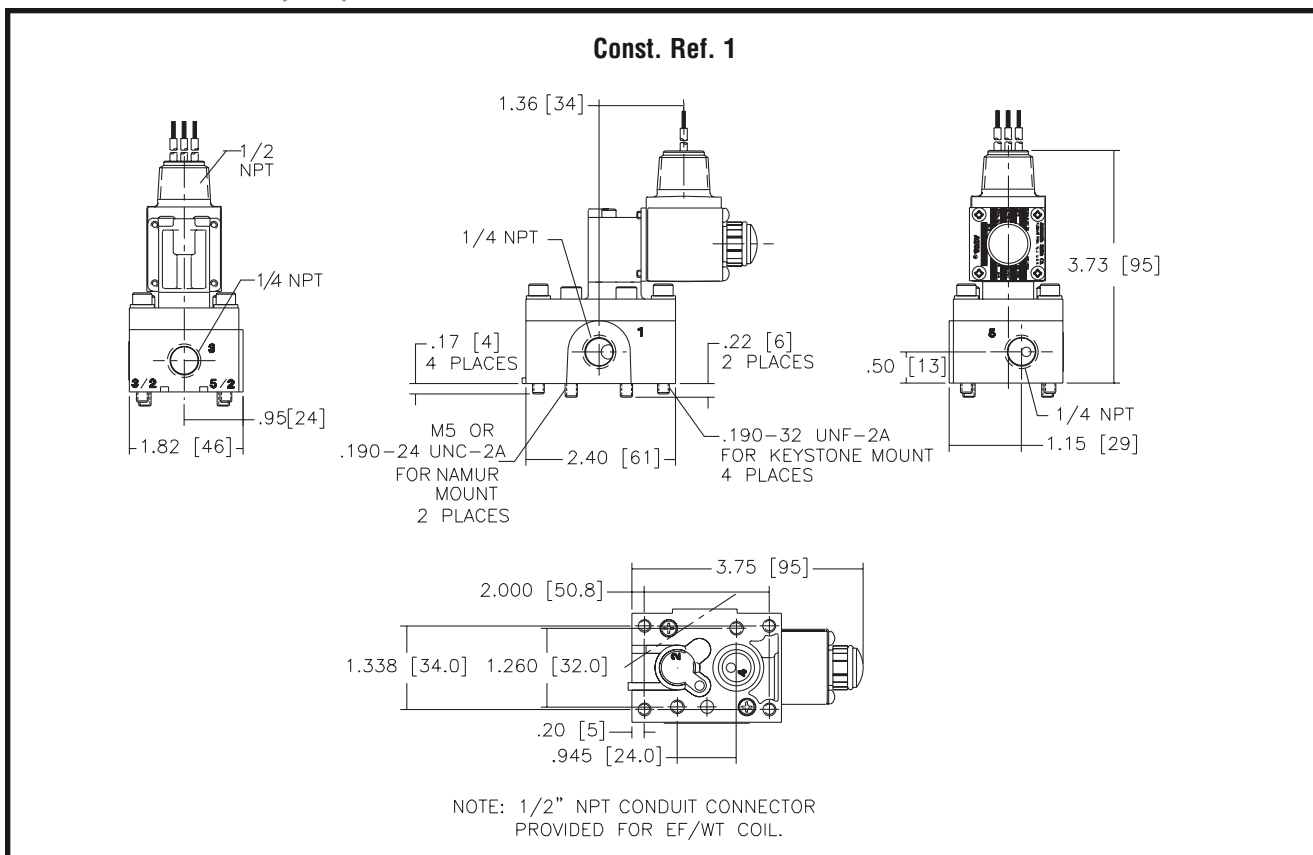

VALVE AUTOMATION

## Dimensions inches (mm)

Const. Ref. 2

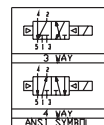
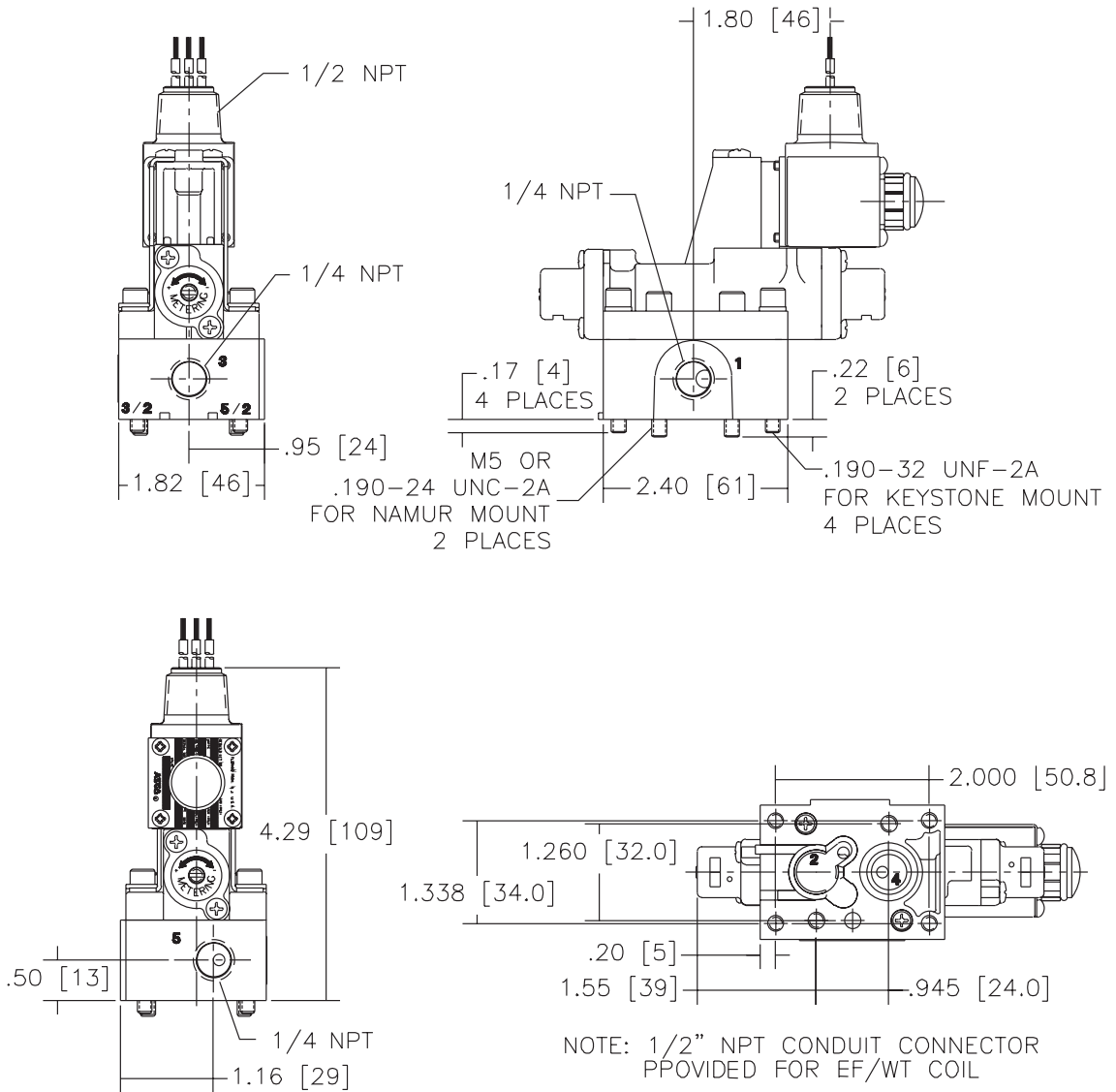

WT8401B202M-27280601

Dimensions inches (mm)

Const. Ref. 3

