

Features

- Unique sliding, sealing member
- Optional flow control regulates cylinder speed in either direction
- Dual solenoid versions hold last position, even after loss of electric power
- Dual solenoid operation: solenoid may be energized momentarily (1/10 second) or continuously
- Air/inert gas service only
- Durable and “non-sticking” sealing method
- Standard manual operator both momentary and maintained
- Optional flow control provides adjustable Cv from 0.2 to 0.8

Construction

Valve Parts in Contact with Fluids	
Main Valve Body, Sub- and Manifold Base, End Caps	Aluminum
Pilot Valve Body	Molded CA
End Caps	Stainless Steel (non-metering) Molded CA (metering)
Seals	NBR (Carboxylated Nitrile)
Spool	Molded Delrin
Slide	Molded Delrin
Flow Plate	Ceramic (alumina)
Core Tube	305 Stainless Steel
Core and Plugnut	430F Stainless Steel
Core and Plugnut	302 Stainless Steel

Electrical

Standard Coil and Class of Insulation	Watt Rating and Power Consumption					
	DC Watts	AC			Spare Coil Part No.	
		Watts	VA Holding	VA Inrush	AC	DC
F	6.9	6.3	8.8	12.1	400125	400125

Standard Voltages: 24, 120, 240, 480 volts AC, 60 Hz (or 110, 220 volts AC, 50 Hz).
 6, 12, 24, 120, 240 volts DC. Must be specified when ordering.
 Other voltages are available when required.

Solenoid Enclosures

Standard: Open Frame Solenoid.

Optional: Watertight, Types 1, 2, 3, 3S, 4, and 4X.

(To order, substitute with prefix “WT”.) Explosionproof and Watertight, Types 3, 3S, 4, 4X, 6, 6P, 7, and 9. (To order, substitute with prefix “EF”.)

See *Optional Features Section* for other available options.

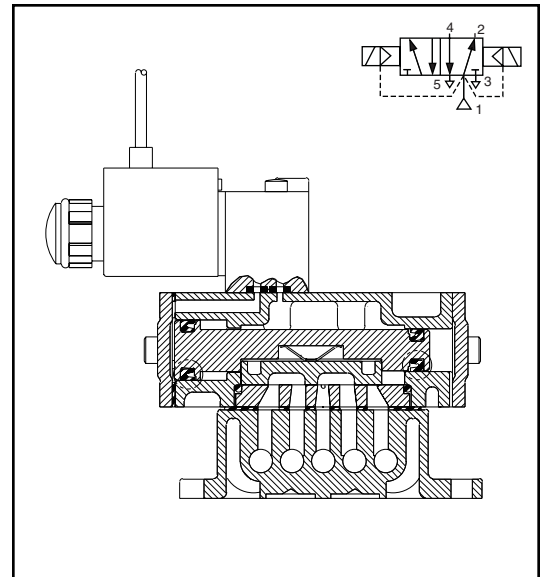
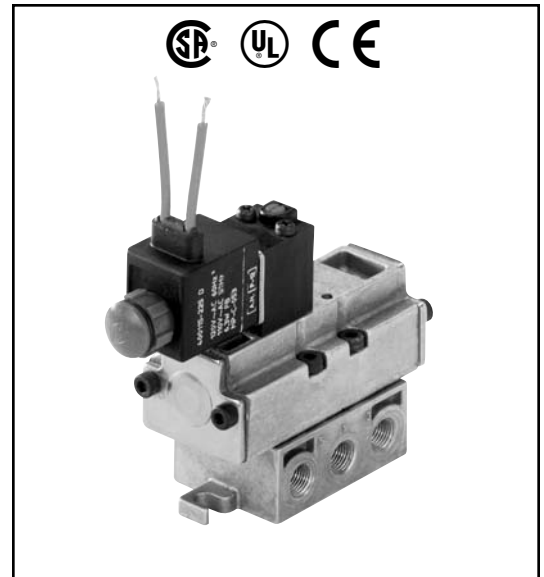

Nominal Ambient Temp. Ranges

Standard Class F insulation:

AC: 0°F to 135°F (-18°C to 57°C) (“U” and “SC” prefix)

AC: 0°F to 104°F (-18°C to 40°C)
 (optional “WT” or “EF” prefix)

DC: 0°F to 77°F (-18°C to 25°C)

Refer to *Engineering Section* for details.

Approvals

CSA certified. UL recognized components for “U” and “SC” prefix. With prefix “WT”, UL listed as a General Purpose Valve. Meets applicable CE directives.

Refer to *Engineering Section* for details.

Specifications (English units)

Pipe Size (ins.)	Orifice Size (ins.)	Cv Flow Factor	Main Line Supply Pressure (psi)			Max. Fluid Temp. °F		Molded Epoxy Open Frame Solenoid				Watt Rating/ Class of Coil Insulation		
			Min.	Air-Inert Gas		AC	DC	Sub-Base Mounted		Manifold Mounted		AC	DC	
				Max. AC	Max. DC			Catalog Number	Const. Ref.	Catalog Number	Const. Ref.			
SINGLE SOLENOID														
1/4	1/4	.80	20	150	150	135	77	U8401B101	1	U8401B103	2	6.3/F	6.9/F	
DUAL SOLENOID														
1/4	1/4	.80	20	150	150	135	77	U8401B105	3	U8401B107	4	6.3/F	6.9/F	

Specifications (Metric units)

Pipe Size (ins.)	Orifice Size (mm)	Kv Flow Factor (m3/h)	Main Line Supply Pressure (bar)			Max. Fluid Temp. °C		Molded Epoxy Open Frame Solenoid				Watt Rating/ Class of Coil Insulation		
			Min.	Air-Inert Gas		AC	DC	Sub-Base Mounted		Manifold Mounted		AC	DC	
				Max. AC	Max. DC			Catalog Number	Const. Ref.	Catalog Number	Const. Ref.			
SINGLE SOLENOID														
1/4	6.4	.69	1.4	10	10	57	25	U8401B101	1	U8401B103	2	6.3/F	6.9/F	
DUAL SOLENOID														
1/4	6.4	.69	1.4	10	10	57	25	U8401B105	3	U8401B107	4	6.3/F	6.9/F	

Dimensions: inches (mm)

Const. Ref.		A	B	C	E	F
1	ins.	.73	.60	.80	1.02	4.43 ①
	mm	19	15	20	26	112 ①
2	ins.	-	-	.79	.91	4.43 ①
	mm	-	-	20	23	112 ①
3	ins.	.73	.60	.80	1.02	-
	mm	19	15	20	26	-

① Add .54 (13.7mm) for metering.
See drawings for dimensions not shown.
Note: "EF" and "WT" dimensions shown by dotted lines.
IMPORTANT: Valve can be mounted in any position.

Const. Ref. 1

Dimensions: inches (mm)

4-WAY

Const. Ref.		A	B	C	E	F	G	H
4*	ins.	-	-	.79	.91	-	-	-
	mm	-	-	20	23	-	-	-

① Add .54 (13.7 mm) for metering. ② Add 1.07 (27.2 mm)
See drawings for dimensions not shown.
Note: "EF" and "WT" dimensions shown by dotted lines. Male 1/2" connection on EF/WT coil, conduit connector provided.
*For dimensions with required end brackets see Const. Ref. 3.
IMPORTANT: Valve can be mounted in any position.

Const. Ref. 4

