



Functional Safety Solutions

for the Process Control Industry

3-way pilot valves

Manual reset & redundant coil pilot valves

Redundant control pilot valve systems



www.ascovalve.com



FUNCTIONAL SAFETY SOLUTIONS

ASCO solenoid pilot valves are an integral part of the final control element for any safety instrumented system (SIS) or critical application. ASCO offers 3 solenoid pilot valve solutions that are widely used in the process control industry; individual 3-way pilot valves, manual reset valves, and redundant pilot valve systems. Each of these solutions are proven in use as a pilot valve in critical applications and in safety instrumented systems. Certified pilot valves per IEC 61508 Parts 1 and 2 are rated SIL 3 capable for domestic and international markets (ATEX). ASCO understands the need to keep your process running, but also understands that the process must shut down when commanded.

3-Way Pilot Valves

ASCO 3-way solenoids, 8314, 8316, and 8320 are the most widely used solenoid pilot valves in the world. For your spring return actuator applications, these valves are proven in use and have undergone 3rd party evaluation by Exida per IEC 61508 Parts 1 & 2. All 3 series are certified SIL 3 capable. Individual pilot valves are most commonly used in 1-out-of-1 voting architectures but can be easily piped into a 2-out-of-2 configuration. ASCO pilot valves are used as the primary device for process valve actuation as well as the shutdown valve when used with digital valve controllers for on-off and control valve applications.

SIL 3 Certified

Manual Reset & Redundant Coil Pilot Valves

ASCO Manual Reset Pilot Valves are a process industry standard. For harsh plant environments where reliability is a must, ASCO has the products to keep your process going. Lever operated manual reset valves are designed with corrosion resistant materials and industrial strength components. When you need to manually engage the final control element of your process system, ASCO has the proven solutions for your applications. Redundant coil pilot valves are also available for your high availability applications.

Redundant Control Pilot Valve Systems

The ASCO RCS is a redundant pilot valve system that acts as a single 3-way valve. The added features of this system above an individual valve include the ability to perform automatic online testing of the redundant solenoid valves, automatic partial stroke testing of the process valve, and online maintenance capabilities. This product is built for high reliability applications and functional safety. The redundant solenoids can operate in 1-out-of-1 Hot Standby mode or 2-out-of-2 Diagnostic mode. Both modes of operation are certified per IEC 61508 Parts 1 and 2 and are SIL 3 capable. To design an RCS product, please visit www.ascovalve.com/RCSConfigurator for the RCS online configurator.

SIL 3 Certified, ATEX Approved

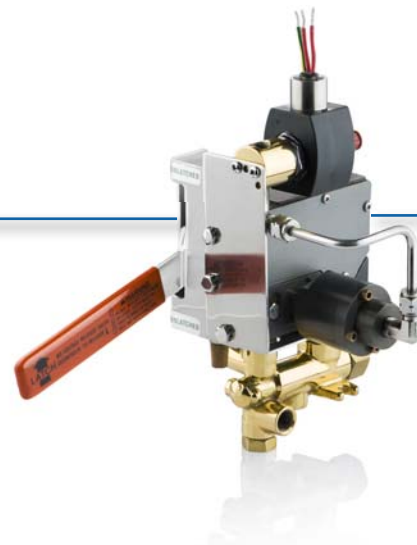
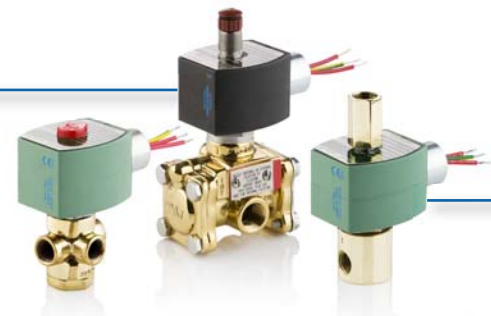



Gas shut-off valves used in burner applications for process heaters are critical to the refining process. This is one of the more common examples of the need for functional safety. In order for the refining process to run without disruption, the valve cannot trip spuriously, and must shut down when commanded in order to avert an unsafe condition.

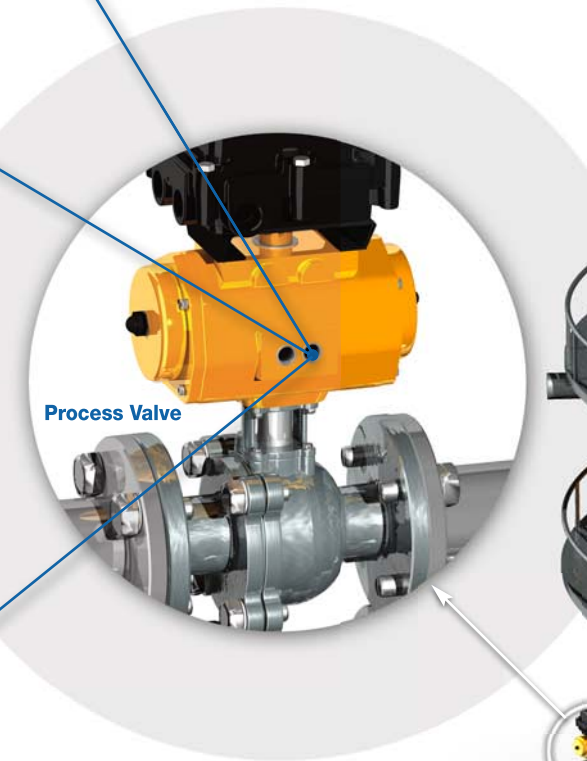

Process Valve

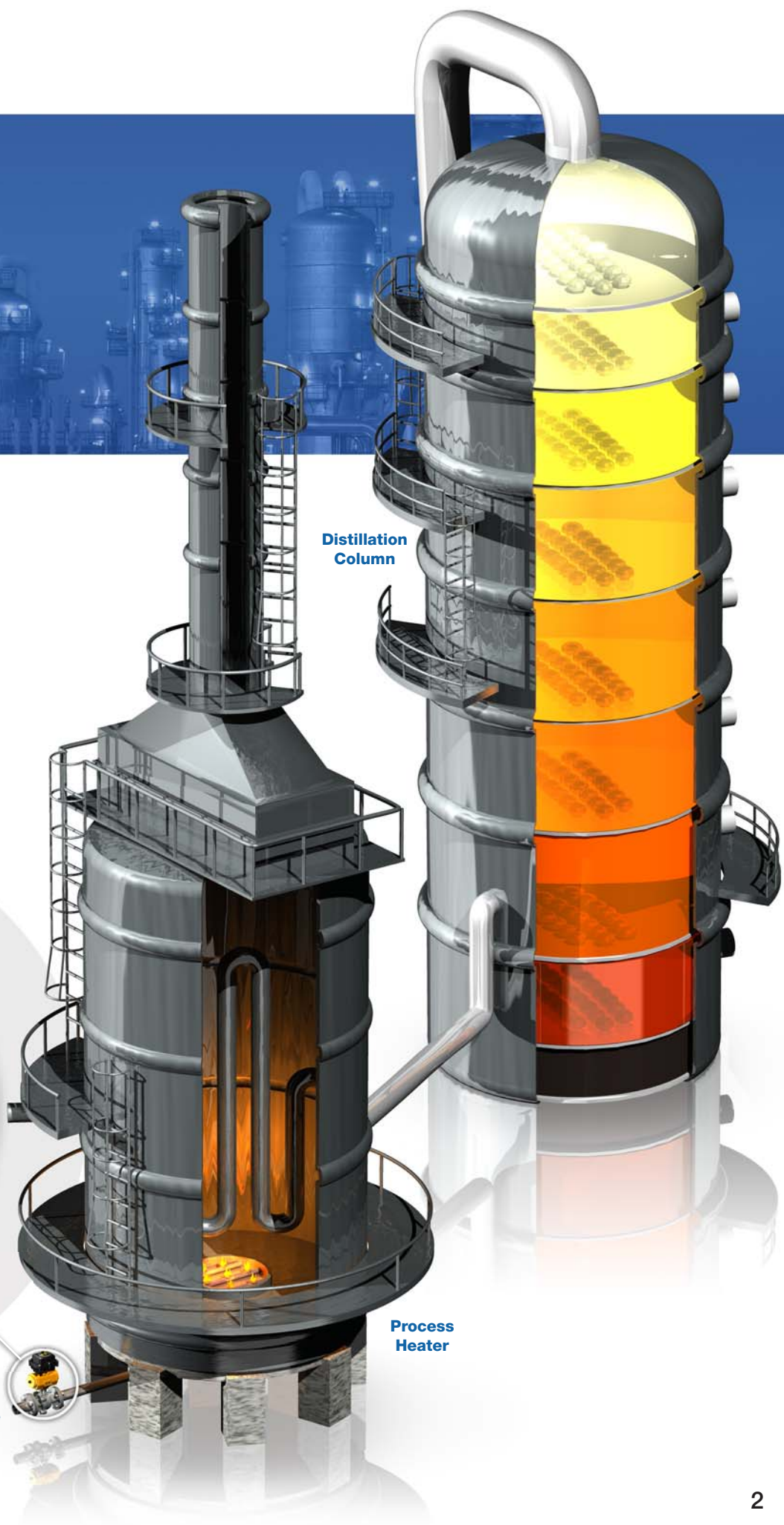

Distillation Column

Process Heater

Fuel Gas Line

Operational Specifications

3-Way Pilot Valves

ASCO IEC 61508 3-way pilot valves are typically piped in the following two configurations:

1 out-of 1

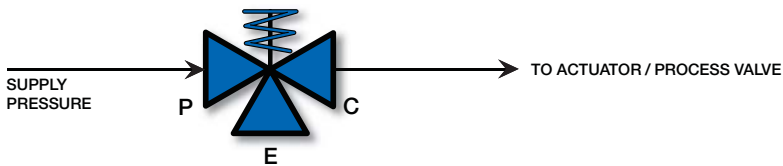

The 1 out-of 1 configuration is the most common pilot valve configuration used.

2 out-of 2

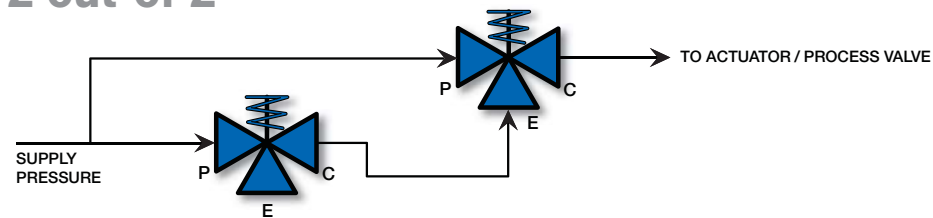

The 2 out-of-2 configurations are commonly used for high availability applications. In the case that one solenoid valve were to spuriously trip, the second solenoid still maintains the position of the actuator/process valve at its operating state. Both solenoids must close in order to shift the actuator/process valve to its non-operating state.

Redundant Coil Pilot Valves

Redundant coil pilot valves are used for high availability applications. There are two coils (solenoid operators) that are redundantly keeping the main solenoid valve in the energized position, which in turn keeps the actuator/process valve in its operating position. Both coils must be de-energized in order to return the actuator/process valve to its non-operating position.

Tamper-Proof Manual Reset Valves

Electrically Tripped – With the pilot valve solenoid de-energized, the handle is raised manually and latches the operator in the “up” (latched) position. Upon energizing the pilot valve solenoid, the latch is tripped returning the operator to the “down” (unlatched) position. If auxiliary air supply to the pilot valve is lost, the main valve will shift position.

No Voltage Release – With the pilot valve solenoid energized, the handle is raised manually and latches the operator in the “up” (latched) position. Upon loss of voltage, the latch is tripped returning the operator to the “down” (unlatched) position. If the auxiliary air supply to the pilot valve is lost, the main valve will shift position.

Moving the handle while the valve is in its tripped state will not cause the actuator/process valve to shift.
(Applies to both tamper-proof manual reset valves)

High Shock Manual Reset Valves

Electrically Tripped – With the pilot valve solenoid de-energized, the handle is raised manually and latches the operator in the “up” (latched) position. Upon energizing the pilot valve solenoid, the latch is tripped returning the operator to the “down” (unlatched) position.

No Voltage Release – With the pilot valve solenoid energized, the handle is raised manually and latches the operator in the “up” (latched) position. Upon loss of voltage, the latch is tripped returning the operator to the “down” (unlatched) position.

Once tripped, the lever may be cycled causing the valve discs to open and close.
(Applies to both high shock manual reset valves)

Important

These solenoids are intended for use on clean, dry air or inert gas filtered to 50 microns or better. To prevent freezing, the dew point of the media should be at least 18°F (-8°C) below the minimum temperature to which any portion of the clean air or gas system could be exposed. Instrument air in compliance with ANSI/ISA Standard S7.3-1975 (R1981) exceeds the above requirements and is, therefore, an acceptable medium for these valves.

3-Way Pilot Valves

Pipe Size (ins.)	Orifice Size (ins.)	Cv Flow Factor	Operating Pressure Differential (psi)						Min. Fluid and Ambient Temp. °F	Max. Fluid Temp. °F		Max. Ambient Temp. °F		Brass Body		Stainless Steel Body		Watt Rating/Class of Coil Insulation	
			Max. AC			Max. DC				AC	DC	AC	DC	Catalog Number	Const. Ref.	Catalog Number	Const. Ref.	AC	DC
			Air-Inert Gas	Water	Lt. Oil @ 45 SSU	Air-Inert Gas	Water	Lt. Oil @ 45 SSU											
NORMALLY CLOSED (Closed when de-energized) – PFD_{AVG} = 4.38 x 10⁻⁴																			
1/8	3/64	.04	230	230	230	120	140	135	32	200	104	125	104	8314G031	1	-	-	10.1/F	11.6/F
1/4	3/64	.04	230	230	230	120	140	135	32	200	104	125	104	8314G034	2	-	-	10.1/F	11.6/F
1/4	3/32	.15	150	100	100	60	70	30	32	200	104	125	104	8314G035	2	8314G121 ①	3	10.1/F	11.6/F
1/4	1/8	.25	75	60	60	30	40	25	32	200	104	125	104	8314G036	2	-	-	10.1/F	11.6/F

① Can be used for **dry** natural gas service with the EF prefix.

3-Way Low Power Pilot Valves (1.4 W)

Pipe Size (ins.)	Orifice Size (ins.)	Cv Flow Factor		Operating Pressure Differential (psi)		Fluid and Ambient Temp. °F		Brass Body		Stainless Steel Body	
		Pressure to Cylinder	Cylinder to Exhaust	Min.	Max.	Min.	Max.	Catalog Number	Const. Ref.	Catalog Number	Const. Ref.
UNIVERSAL OPERATION (Pressure at any port) with NBR Disc – PFD_{AVG} = 4.38 x 10⁻⁴											
1/4	1/16	.08	.08	0	150	-40	140	8314G300	4	8314G301 ⑥	5
NORMALLY CLOSED (Closed when de-energized) with NBR Disc or FPM, as Listed – PFD_{AVG} = 7.01 x 10⁻⁴											
1/4	5/16	1.5	1.5	⑤	150	-4	140	8316G301 ③	6	EV8316G381V ④⑥	6
3/8	5/16	1.8	1.8	⑤	150	-4	140	8316G302 ③	6	EV8316G382V ④⑥	6
3/8	5/8	4	4	⑤	150	-4	140	8316G303 ③	7	-	-
1/2	5/8	4	4	⑤	150	-4	140	8316G304 ③	7	EV8316G384V ④⑥	7
3/4	11/16	5.5	5.5	10	150	-4	140	8316H374 ③	8	-	-
1	1	13	13	10	150	-4	140	8316G334 ③	9	-	-

③ **IMPORTANT:** A Minimum Operating Pressure Differential must be maintained between the pressure and exhaust ports. Supply and exhaust piping must be full area, unrestricted. ASCO flow controls and other similar components must be installed in the cylinder lines only. See graph on page 7 for main line pressure vs. pilot line pressure.

④ Diaphragm and main disc FKM only (pilot is low-temperature NBR).

⑤ Zero minimum when valve selection gasket is in external position and proper auxiliary air pressure is applied. Minimum 15 psi Operating Pressure Differential when selection gasket is in the internal position.

⑥ Can be used for **dry** natural gas service with the EF or EV prefix.

3-Way Pilot Valves

Pipe Size (ins.)	Orifice Size (ins.)	Cv Flow Factor	Operating Pressure Differential (psi)						Min. Fluid and Ambient Temp. °F	Max. Fluid Temp. °F		Max. Ambient Temp. °F		Brass Body		Stainless Steel Body		Watt Rating/Class of Coil Insulation ②	
			Max. AC			Max. DC				AC	DC	AC	DC	Catalog Number	Const. Ref.	Catalog Number	Const. Ref.	AC	DC
			Air-Inert Gas	Water	Lt. Oil @ 300 SSU	Air-Inert Gas	Water	Lt. Oil @ 300 SSU											
NORMALLY CLOSED (Closed when de-energized) – PFD_{AVG} = 4.38 x 10⁻⁴																			
1/8	3/64	.06	200	200	200	200	200	200	32	180	120	125	104	8320G132	10	8320G142 ③	10	6.1/F	10.6/F
1/8	1/16	.09	150	125	125	125	125	125	32	180	120	125	104	8320G013	10	8320G045 ③	10	6.1/F	10.6/F
1/8	3/32	.12	100	100	100	100	100	100	32	180	120	125	104	8320G015	10	8320G047 ③	10	6.1/F	10.6/F
1/8	1/8	.21	40	40	40	40	40	40	32	180	120	125	104	8320G017	10	8320G049 ③	10	6.1/F	10.6/F
1/4	1/16	.09	210	225	225	160	160	160	32	200	150	125	104	8320G182	11	-	-	17.1/F	11.6/F
1/4	3/32	.12	150	150	150	115	115	115	32	200	150	125	104	8320G184	11	8320G202 ③	12	10.1/F	11.6/F
1/4	1/8	.25	85	85	85	60	60	60	32	200	150	125	104	8320G186	11	8320G203 ③	12	10.1/F	11.6/F
1/4	11/64	.35	45	45	45	25	25	25	32	200	150	125	104	8320G188	11	-	-	10.1/F	11.6/F
NORMALLY OPEN (Open when de-energized) – PFD_{AVG} = 5.04 x 10⁻⁴																			
1/8	3/64	.06	200	200	200	200	200	200	32	180	120	125	104	8320G136	10	8320G146 ③	10	6.1/F	10.6/F
1/8	1/16	.09	150	125	125	125	125	125	32	180	120	125	104	8320G027	10	8320G051 ③	10	6.1/F	10.6/F
1/8	3/32	.12	100	100	100	100	100	100	32	180	120	125	104	8320G029	10	8320G053 ③	10	6.1/F	10.6/F
1/8	1/8	.21	40	40	40	40	40	40	32	180	120	125	104	8320G031	10	8320G055 ③	10	6.1/F	11.6/F
1/4	1/16	.09	250	250	250	160	160	160	32	200	150	125	104	8320G192	11	-	-	17.1/F	11.6/F
1/4	3/32	.12	150	140	140	100	100	100	32	200	150	125	104	8320G194	11	8320G204 ③	12	10.1/F	11.6/F
1/4	1/8	.25	70	70	70	55	55	55	32	200	150	125	104	8320G196	11	8320G205 ③	12	10.1/F	11.6/F
1/4	11/64	.35	40	40	40	30	30	30	32	200	150	125	104	8320G198	11	-	-	10.1/F	11.6/F

② On 50 hertz service, the watt rating for the 6.1/F solenoid is 8.1 watts; the watt rating for the 9.1/F solenoid is 11.1 watts.

③ Can be used for **dry** natural gas service with the EF or EV prefix.

Dimensions: inches [mm]

Const. Ref.		H	K	L	P	W
1	ins.	3.87	1.67	Ø1.19	3.51	1.95
	mm	98	42	Ø30	89	50
2	ins.	4.21	1.80	Ø1.25	3.79	1.95
	mm	107	46	Ø32	96	50
3	ins.	4.14	1.78	Ø1.63	3.77	1.95
	mm	105	45	Ø41	96	50

IMPORTANT: Valves can be mounted in any position.

Const. Ref. 1, 2, 3

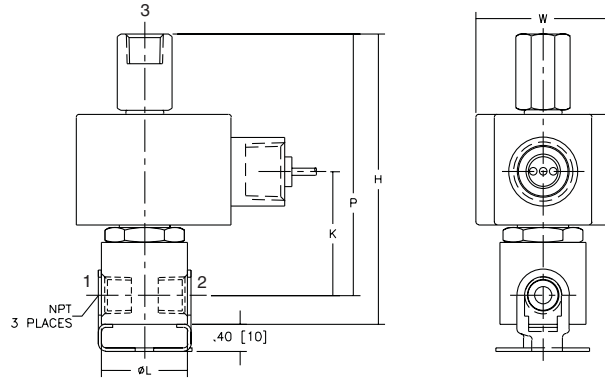

Const. Ref. 4, 5

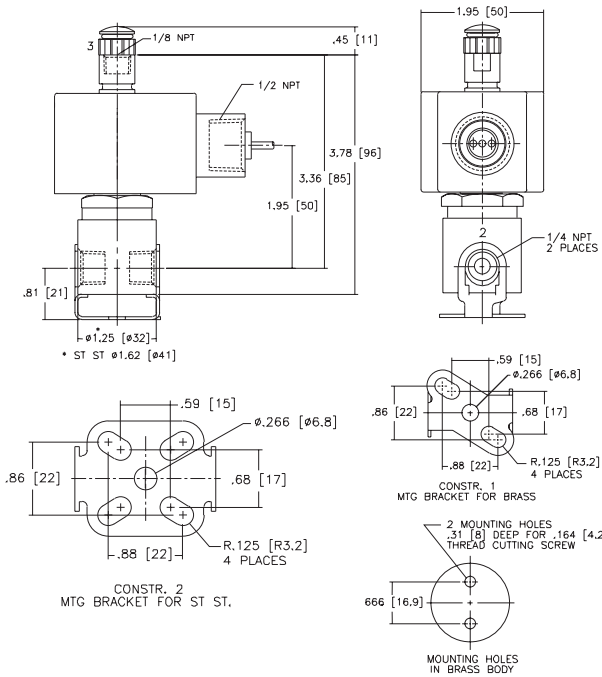

Const. Ref. 6

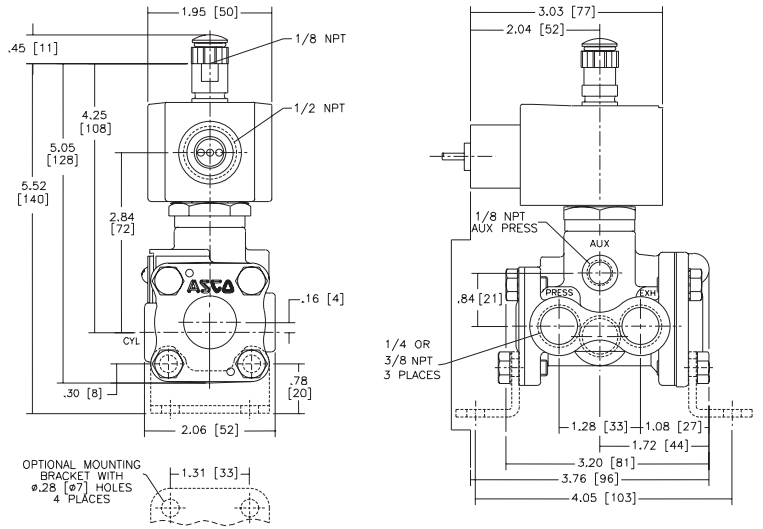

Const. Ref. 7

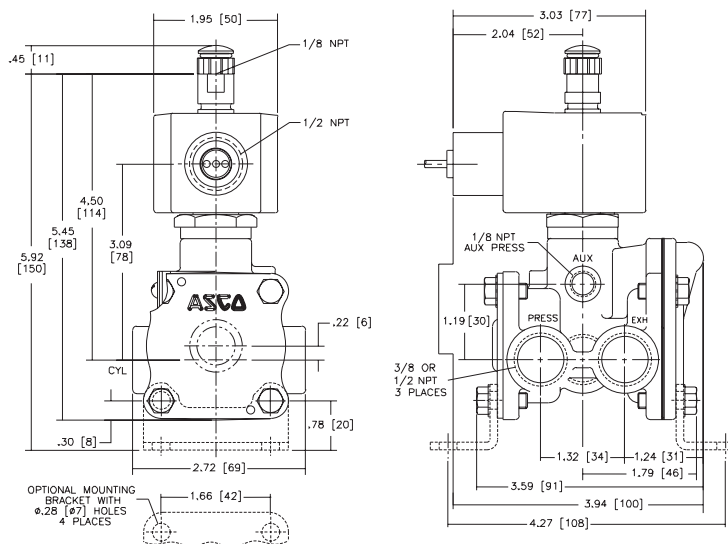

Dimensions: inches [mm]

Const. Ref.		A	B	C	H	K	L	M	N	P	R	W
8	ins.	1.61	1.41	1.66	6.78	3.68	3.38	2.16	.53	5.09	.50	3.31
	mm	41	36	42	172	93	86	55	13	129	13	84
9	ins.	X	1.78	X	7.40	3.93	4.44	2.81	.87	5.34	1.74	5.31
	mm	X	45	X	188	100	113	71	22	136	44	135

Const. Ref. 8, 9

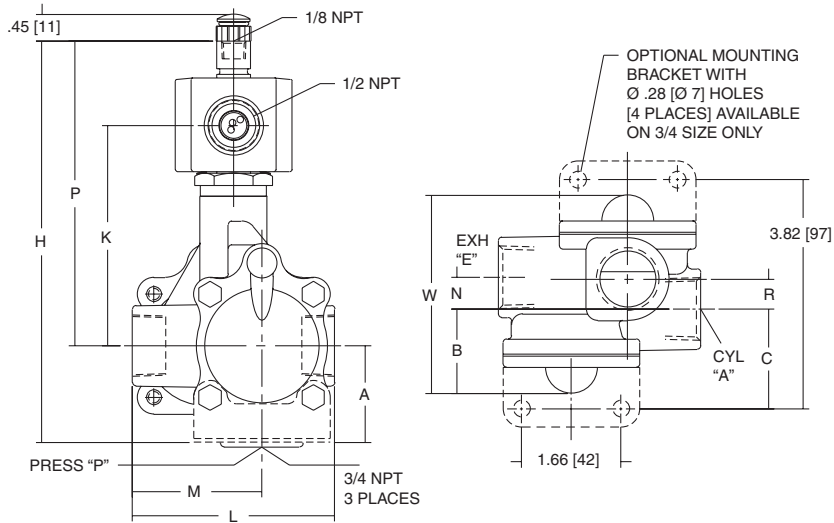

Const. Ref. 10

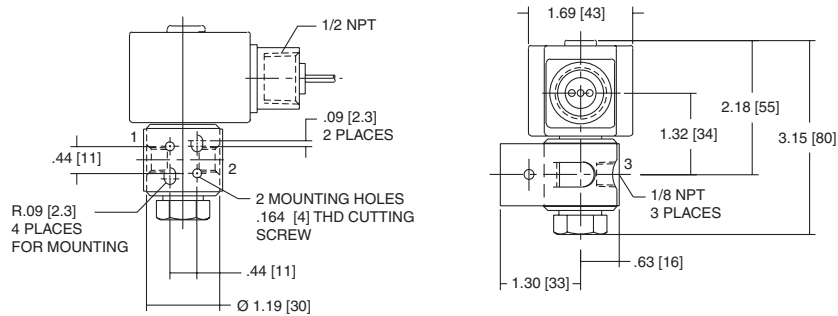

Const. Ref. 11

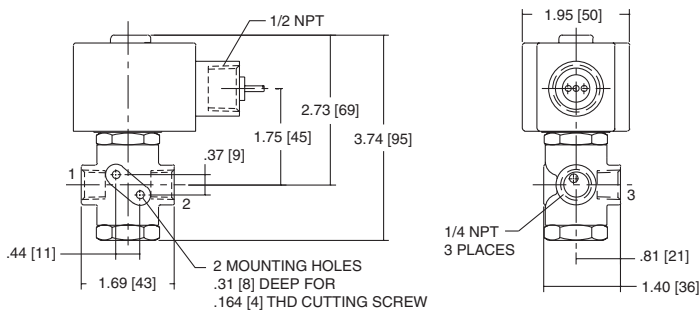

Const. Ref. 12

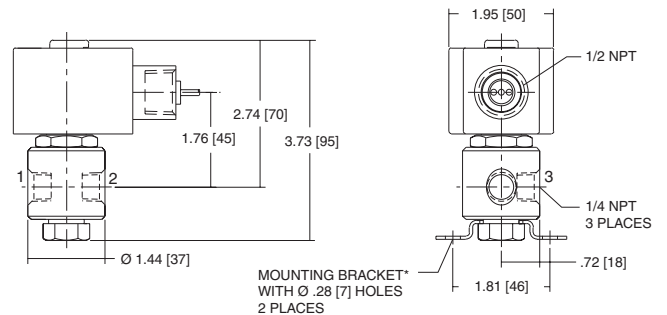

* MOUNTING BRACKET IS STANDARD ON THIS CONSTRUCTION

Manual Reset and Redundant Coil Pilot Valves

Pipe Size (ins.)	Orifice Size (ins.)	Cv Flow Factor	Operating Pressure Differential (psi)			Fluid Temp. °F		Max. Ambient Temp. °F	Catalog Number	Const. Ref.	Body Material	Pilot Construction	Watt Rating/ Class of Coil Insulation per Solenoid	
			Pilot Min.	Pilot Max.	Main Max.	Min.	Max.						AC	DC
3/2 Redundant Coil Pilot Valves														
1/4	3/64	.04	-	-	150	-40	140	140	EV8323G352	13	Stainless Steel	Normally Closed	-	1.4/F
1/4	3/64	.04	-	-	150	-40	140	140	EV8323G353	13	Stainless Steel	Normally Open	-	1.4/F
1/4	3/64	.04	-	-	150	-4	200	125	EV8323G052	13	Stainless Steel	Normally Closed	10.1/F	-
1/4	3/64	.04	-	-	150	-4	200	125	EV8323G053	13	Stainless Steel	Normally Open	10.1/F	-
1/4	5/16	1.5	①	150	150	-4	180	125	EF8323G060	14	Brass	Normally Closed	10.1/F	-
1/4	5/16	1.5	①	150	150	-4	180	125	EV8323G080	14	Stainless Steel	Normally Closed	10.1/F	-
1/4	5/16	1.5	①	150	150	-4	180	125	EV8323G082	14	Stainless Steel	Normally Open	10.1/F	-
1/4	5/16	1.5	①	150	150	-4	140	140	EV8323G380	14	Stainless Steel	Normally Closed	-	1.4/F
1/4	5/16	1.5	①	150	150	-4	140	140	EV8323G382	14	Stainless Steel	Normally Open	-	1.4/F
1/2	5/8	4	①	150	150	-4	180	125	EV8323G081	15	Stainless Steel	Normally Closed	10.1/F	-
1/2	5/8	4	①	150	150	-4	180	125	EV8323G083	15	Stainless Steel	Normally Open	10.1/F	-
1/2	5/8	4	①	150	150	-4	140	140	EV8323G381	15	Stainless Steel	Normally Closed	-	1.4/F
1/2	5/8	4	①	150	150	-4	140	140	EV8323G383	15	Stainless Steel	Normally Open	-	1.4/F
3/2 Tamper Proof Manual Reset Valves														
1/4	5/16	1.5	25	125	150	-4	180	125	EV8308G060	16	Stainless Steel	No Voltage Release (NVR)	10.1/F	-
1/4	5/16	1.5	25	125	150	-4	140	140	EV8308G360	16	Stainless Steel	No Voltage Release (NVR)	-	1.4/F
1/2	5/8	4	25	125	150	-4	180	125	EV8308G061	17	Stainless Steel	No Voltage Release (NVR)	10.1/F	-
1/2	5/8	4	25	125	150	-4	140	140	EV8308G361	17	Stainless Steel	No Voltage Release (NVR)	-	1.4/F
3/2 High Shock Manual Reset Valves														
3/8	1/4	0.45	25	125	125	-40	140	140	EV8308G385	18	Brass	No Voltage Release (NVR)	-	1.4/F
3/8	1/4	0.45	25	125	125	-40	140	140	EV8310G385	18	Brass	Electrically Tripped (TSO)	-	1.4/F
3/8	1/4	0.45	25	125	125	-4	200	125	EV8308G085	18	Brass	No Voltage Release (NVR)	10.1/F	-
3/8	1/4	0.45	25	125	125	-4	200	125	EV8310G085	18	Brass	Electrically Tripped (TSO)	10.1/F	-
3/8	1/4	0.45	25	125	125	-40	140	140	EV8308G386	18	Stainless Steel	No Voltage Release (NVR)	-	1.4/F
3/8	1/4	0.45	25	125	125	-40	140	140	EV8310G386	18	Stainless Steel	Electrically Tripped (TSO)	-	1.4/F
3/8	1/4	0.45	25	125	125	-4	200	125	EV8308G086	18	Stainless Steel	No Voltage Release (NVR)	10.1/F	-
3/8	1/4	0.45	25	125	125	-4	200	125	EV8310G086	18	Stainless Steel	Electrically Tripped (TSO)	10.1/F	-

① Zero minimum when valve selection gasket is in external position and proper auxiliary air pressure is applied.
See graph below for main line pressure vs. pilot line pressure. Minimum 15 psi operating pressure differential when selection gasket is in the internal position.

Dimensions: inches [mm]

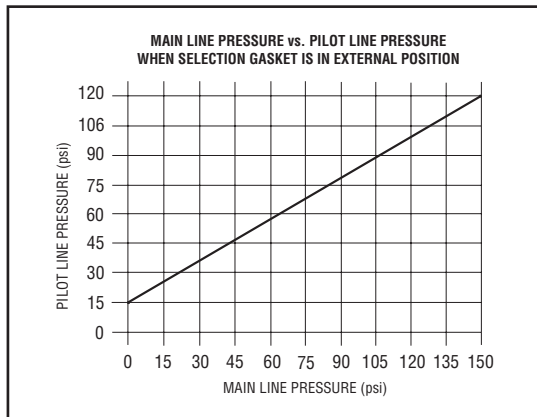

Const. Ref. 14

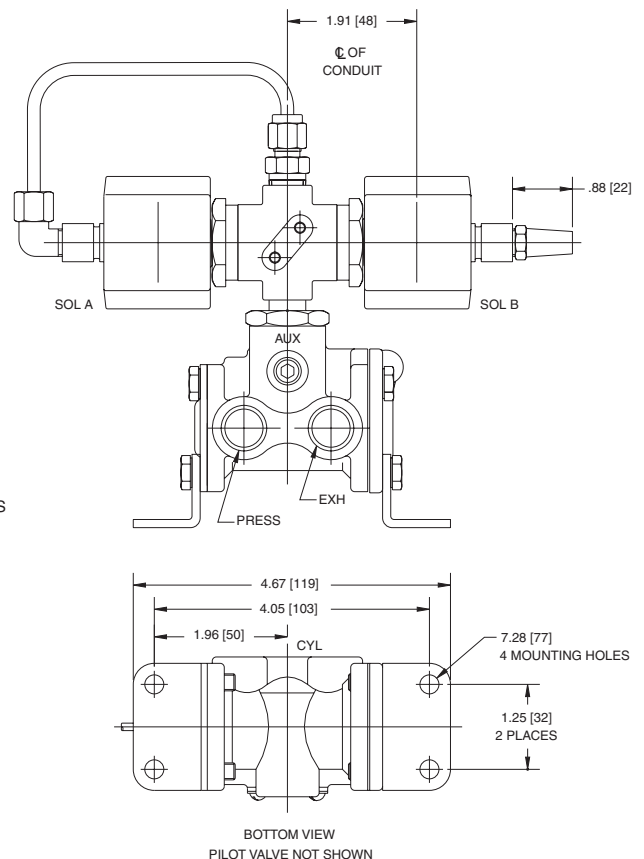

Const. Ref. 13

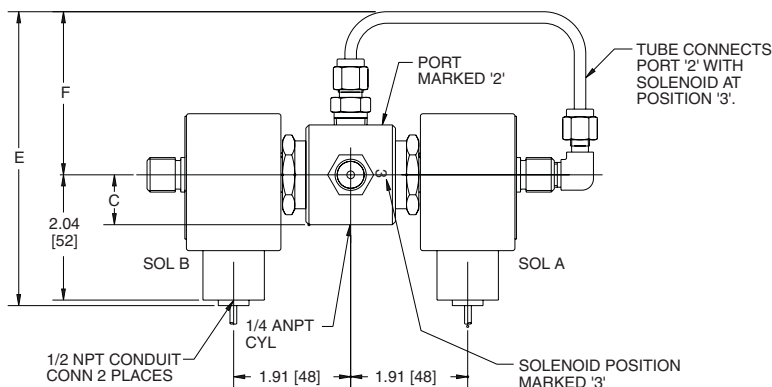

Const. Ref. 15

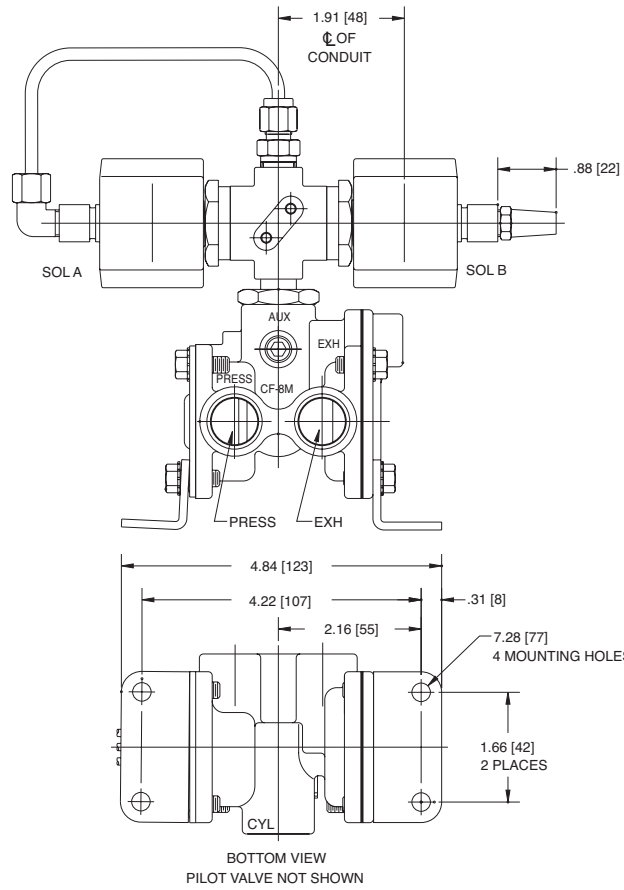

Const. Ref. 16

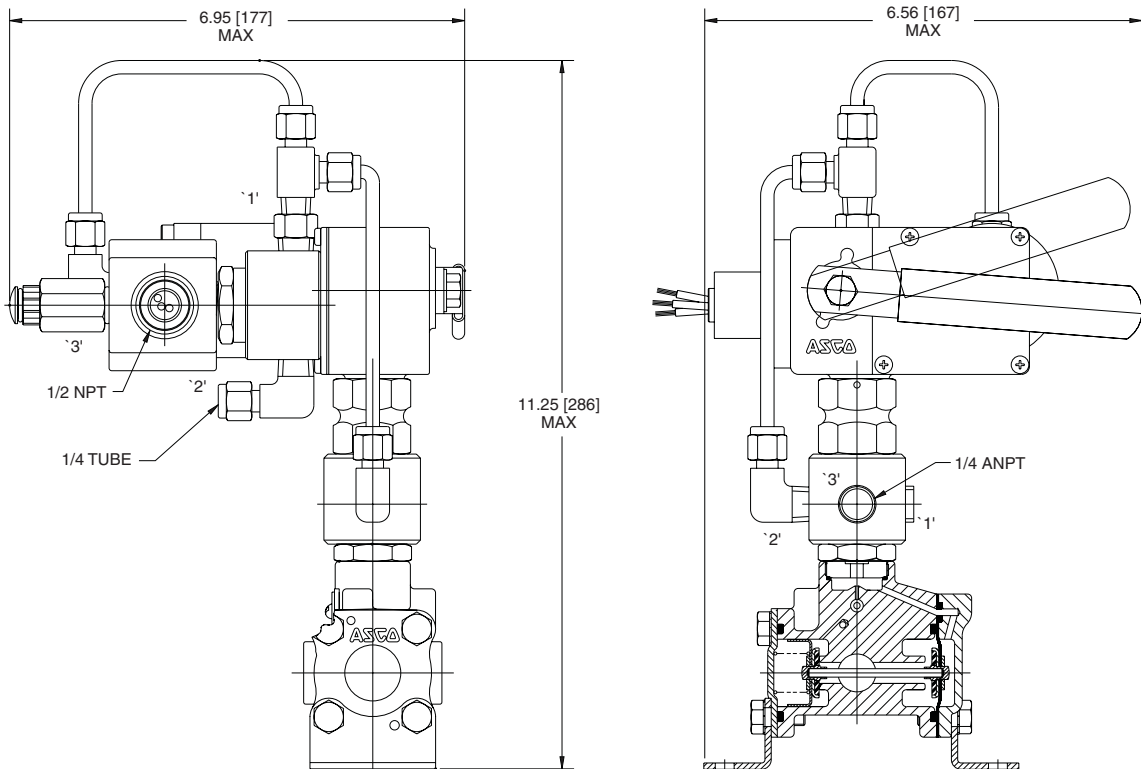

Const. Ref. 17

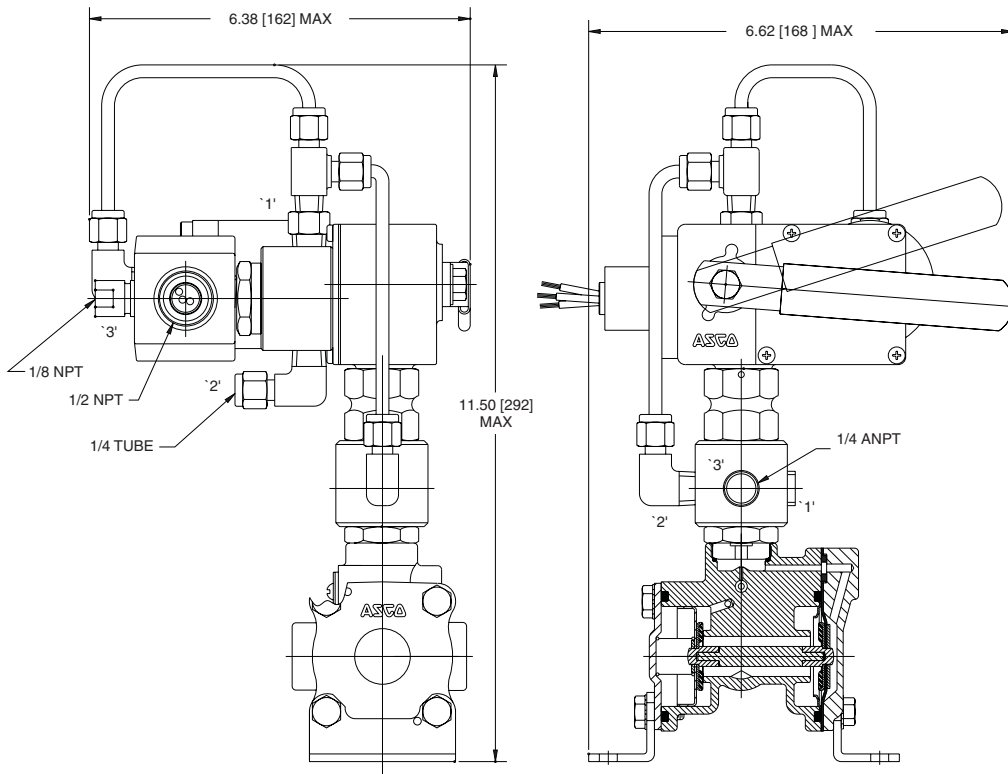

Const. Ref. 18

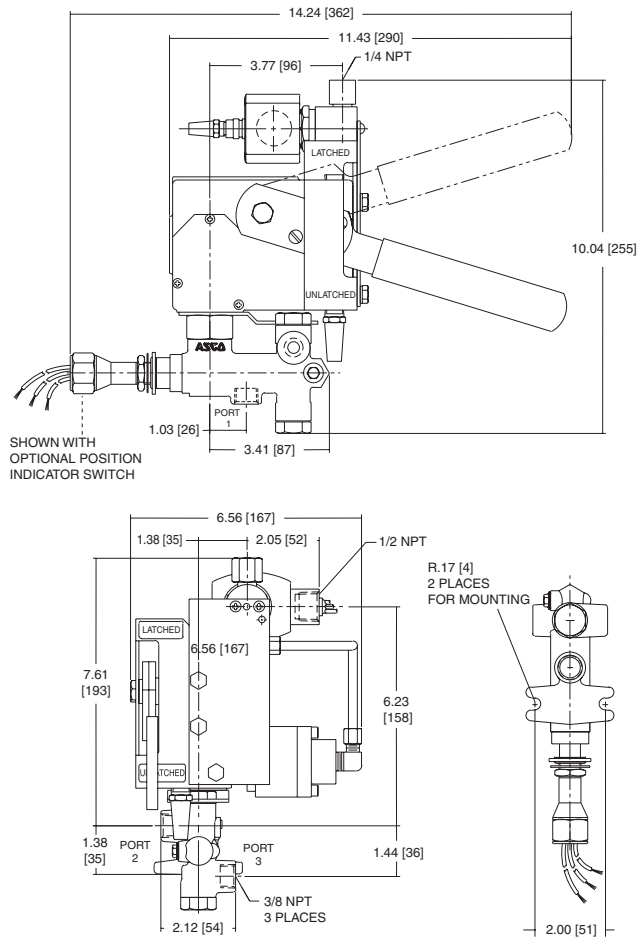

Redundant Control Pilot Valve Systems

ASCO simplified the RCS product selection process with an online catalog number configurator. Once you have determined the features required, you can easily construct a catalog number by clicking on each feature required and then clicking the **View Details** button. A second screen appears providing the product catalog number, product attributes, and various drawings. The configurator is programmed to accept only valid constructions.

In addition to creating a catalog number, the configurator can also decipher a catalog number. Type a valid 5RC or 5LC catalog number into the window next to the **Enter Catalog Number** button (CAPs only). The configurator automatically highlights the appropriate construction features.

In order to use the online configurator go to: www.ascovalve.com/RCSConfigurator

To ensure that you are familiar with the RCS product line, we recommend that you read the RCS catalog prior to designing a product.

Design a Redundant Control System

* Indicates a required attribute

<table border="1" style="width: 100%; border-collapse: collapse;"> <tr> <th style="text-align: center;">* On board Diagnostic Processor</th> </tr> <tr> <td style="background-color: #e0f0e0;">None</td> </tr> <tr> <td>Standard: 32°F to 131°F (0°C to 55°C)</td> </tr> <tr> <td>Extended Temperature: -13°F to 158°F (-25°C to 70°C)</td> </tr> </table>	* On board Diagnostic Processor	None	Standard: 32°F to 131°F (0°C to 55°C)	Extended Temperature: -13°F to 158°F (-25°C to 70°C)	<table border="1" style="width: 100%; border-collapse: collapse;"> <tr> <th style="text-align: center;">* Configuration</th> </tr> <tr> <td style="background-color: #e0f0e0;">Normally Closed</td> </tr> <tr> <td>Normally Open</td> </tr> <tr> <td>Double Acting</td> </tr> </table>	* Configuration	Normally Closed	Normally Open	Double Acting	<h3 style="margin: 0;">Information</h3> <div style="border: 1px solid gray; height: 100px; width: 100%;"></div>									
* On board Diagnostic Processor																			
None																			
Standard: 32°F to 131°F (0°C to 55°C)																			
Extended Temperature: -13°F to 158°F (-25°C to 70°C)																			
* Configuration																			
Normally Closed																			
Normally Open																			
Double Acting																			
<table border="1" style="width: 100%; border-collapse: collapse;"> <tr> <th style="text-align: center;">* Enclosure Material</th> </tr> <tr> <td>304 Stainless Steel</td> </tr> <tr> <td style="background-color: #e0f0e0;">316 Stainless Steel</td> </tr> <tr> <td>Composite (Fiberglass)</td> </tr> </table>	* Enclosure Material	304 Stainless Steel	316 Stainless Steel	Composite (Fiberglass)	<table border="1" style="width: 100%; border-collapse: collapse;"> <tr> <th style="text-align: center;">* System Voltage</th> </tr> <tr> <td>12 VDC</td> </tr> <tr> <td style="background-color: #e0f0e0;">24 VDC</td> </tr> <tr> <td>48 VDC</td> </tr> <tr> <td>120 VDC</td> </tr> <tr> <td>120/60-110/50</td> </tr> <tr> <td>24 VDC Intrinsically Safe</td> </tr> <tr> <td>230/50-240/50</td> </tr> </table>	* System Voltage	12 VDC	24 VDC	48 VDC	120 VDC	120/60-110/50	24 VDC Intrinsically Safe	230/50-240/50	<table border="1" style="width: 100%; border-collapse: collapse;"> <tr> <th style="text-align: center;">* Operational Mode</th> </tr> <tr> <td>Energized to Trip</td> </tr> <tr> <td style="background-color: #e0f0e0;">De-Energized to Trip</td> </tr> <tr> <td>1oo1HS De-Energized to Trip</td> </tr> <tr> <td>2oo2 De-Energized to Trip</td> </tr> </table>	* Operational Mode	Energized to Trip	De-Energized to Trip	1oo1HS De-Energized to Trip	2oo2 De-Energized to Trip
* Enclosure Material																			
304 Stainless Steel																			
316 Stainless Steel																			
Composite (Fiberglass)																			
* System Voltage																			
12 VDC																			
24 VDC																			
48 VDC																			
120 VDC																			
120/60-110/50																			
24 VDC Intrinsically Safe																			
230/50-240/50																			
* Operational Mode																			
Energized to Trip																			
De-Energized to Trip																			
1oo1HS De-Energized to Trip																			
2oo2 De-Energized to Trip																			

Optional Features	
Common Alarm	Full Stroke Limit Switch
Modbus 485 Communication	Dual Power Sources
Local Initiation of Sov Test	Analog Input Module
Local Initiation of Partial Stroke Test	Two Analog Input Modules
Local Manual Reset	Cabinet Heater
Bypass Indication	Lever Type Bypass
Midstroke Limit Switch	Shutoff for Modulated Control Valves
Silver Contacts for Relay Logic	No Bypass
SIL Certification	ATEX Certification

Additional Lights and Push Buttons		
One Green Light	One Green & One Red Light	One Push Button
Two Green Lights	Two Green & One Red Light	Two Push Buttons
Three Green Lights	Three Green & One Red Light	Three Push Buttons
Four Green Lights	One Green & Two Red Lights	Four Push Buttons
One Red Light	One Green & Three Red Lights	
Two Red Lights	Two Green & Two Red Lights	
Three Red Lights		
Four Red Lights		

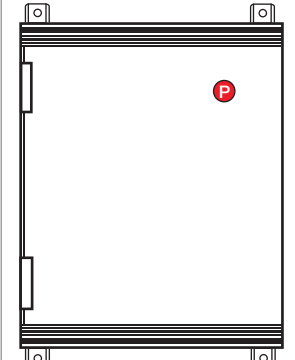

Canada
Tel 519-758-2700

Australia
Tel (61) 2-9-451-7077

Brazil
Tel (55) 11-4208-1660

Mexico
Tel (52-1) 728-28-51-238

France
Tel (33) 1-47-14-32-00

Germany
Tel (49)-7237-9960

United Kingdom
Tel (44) 1695-713600

China
Tel (86-28) 8662-8833

Singapore
Tel (65) 6556-1100

Japan
Tel (81) 798-65-6361