

Features

- Designed for harsh, hazardous environments, including offshore applications
- Provides quick shutdown of valves and actuators
- Low power DC for solar panels and PLC control
- Factory-sealed leads
- Explosionproof Types 4 and 7, Class I, Division 1, Groups C and D protection, or ATEX EEx d IIB T6 with EC or ED prefix
- Mountable in any position

Construction

Valve Parts in Contact with Fluids	
Body	316 Stainless Steel
Seals and Disc	FKM
Core and Plugnut	430F Stainless Steel
Core Spring	302 Stainless Steel
Rider Rings	PTFE
Disc-Holder and Core Guide	CA

Electrical

Standard Coil and Class of Insulation	Watt Rating and Power Consumption
	DC Watts
F	1.44
F	2.88

Standard Voltages: 12 and 24 volts DC.

Solenoid Enclosures

Standard: 316 Stainless Steel, Explosionproof and Watertight with 72" leads. Types 1, 2, 3, 4, 4X, 6, 6P, 7, and 9, Class I, Division 1, Groups C & D.

Optional: For ATEX approved valves with 20mm conduit connection use prefix "EC" instead of "EF". Use prefix "ED" for 1/2" NPT conduits.

See Engineering Section under "Enclosures" for details.

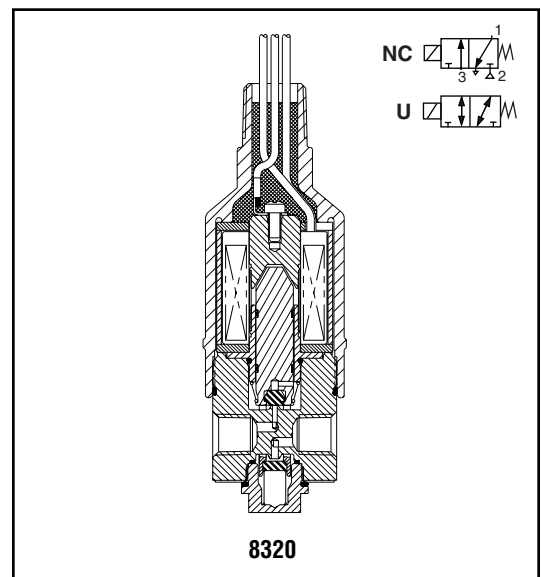

SPECIAL SERVICE PILOT

Nominal Ambient Temp. Ranges

-4°F to 120°F (-20°C to 49°C)

Refer to Engineering Section for details.

Approvals

UL listed, CSA certified General Purpose valve, hazardous location classified.

Meets applicable CE directives.

Electric Solenoid Operator

ATEX category 2G

II 2G Ex d IIB T6; Ta = -20°C to 49°C

DEMCO 03 ATEX 0238269

Refer to Engineering Section for details.

Specifications (English units)

Pipe Size (ins.)	Orifice Size (ins.)		Cv Flow Factor		Operating Pressure Differential (psi)				Watt Rating/ Class of Coil Insulation 12 or 24 VDC
	Pressure	Exhaust	Pressure	Exhaust	Air/Natural Gas		Catalog Number	Const. Ref.	
					Min.	Max.			
NORMALLY CLOSED (Closed when de-energized)									
1/4	1/16	3/32	0.08	0.16	0	150 ①	EF8320511	1	2.88/F
1/4	1/16	3/32	0.08	0.16	0	55	EF8320512	1	1.44/F
1/4	1/16	1/4	0.08	1.4	15	150	EF8317511 ③	2	2.88/F
1/4	1/16	1/4	0.08	1.4	15	55	EF8317512 ③	2	1.44/F
1/4	1/16	3/8	1.1	1.2	20	150	EF8321511 ②	3	2.88/F
1/4	1/16	3/8	1.1	1.2	20	55	EF8321512 ②	3	1.44/F
UNIVERSAL FLOW (Pressure at any port)									
1/4	1/16	3/32	0.08	.16	0	65	EF8320515	1	2.88/F

① Light Oil Max Pressure 100 psi (7 bar). ② Main disc is NBR ③ This valve has a Hytrel diaphragm..

Specifications (Metric units)

Pipe Size (ins.)	Orifice Size (mm)		Kv Flow Factor (m3/h)		Operating Pressure Differential (bar)				Watt Rating/ Class of Coil Insulation 12 or 24 VDC
	Pressure	Exhaust	Pressure	Exhaust	Air/Natural Gas		Catalog Number	Const. Ref.	
					Min.	Max.			
NORMALLY CLOSED (Closed when de-energized)									
1/4	1.6	2.4	0.07	0.14	0	10 ①	EF8320511	1	2.88/F
1/4	1.6	2.4	0.07	0.14	0	4	EF8320512	1	1.44/F
1/4	1.6	6.4	0.07	1.2	1	10	EF8317511 ③	2	2.88/F
1/4	1.6	6.4	0.07	1.2	1	4	EF8317512 ③	2	1.44/F
1/4	1.6	9.5	0.95	1.1	1.4	10.3	EF8321511 ②	3	2.88/F
1/4	1.6	9.5	0.95	1.2	1.4	3.8	EF8321512 ②	3	1.44/F
UNIVERSAL FLOW (Pressure at any port)									
1/4	1.6	2.4	0.07	0.14	0	4	EF8320515	1	2.88/F

Dimensions: inches (mm)

