

Features

- Design eliminates metal-to-metal contact to extend life up to 20 million cycles in dry air or gas applications
- Internal AC hum and metallic click at energization are eliminated. Quiet operating
- Easily handles applications involving rapid cycling or continuous energization

Construction

Valve Parts in Contact with Fluids	
Core Bumpers	UR
Rider Rings	PTFE

For more information, see individual Series in General Service Valve Section.

Electrical

Standard Coil and Class of Insulation	Watt Rating and Power Consumption				Spare Coil Part Number	
	DC Watts	AC			General Purpose	Explosionproof
		Watts	VA Holding	VA Inrush	AC	AC
F	①	15.1	22	22	270110	270114

Standard Voltages: 24, 120, 240, 480 volts AC, 60 Hz (or 110, 220 volts AC, 50 Hz). Must be specified when ordering.

Note: ① Consult your local ASCO sales office for DC voltages.

Solenoid Enclosures

Standard: Watertight, Types 1, 2, 3, 3S, 4, and 4X.

Optional: Explosionproof and Watertight, Types 3, 3S, 4, 4X, 6, 6P, 7, and 9. (To order, add prefix "EF" to catalog number.)

See *Optional Features Section* for other available options.

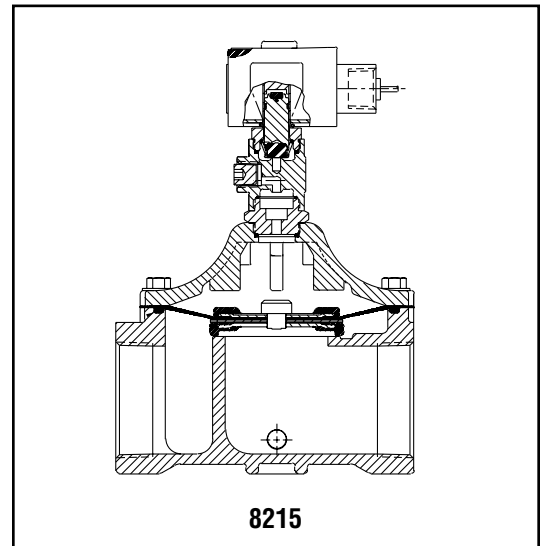

SPECIAL SERVICE VALVES

Nominal Ambient Temp. Ranges

Series 8262: 32°F to 131°F (0°C to 55°C)*

* Max. ambient for explosionproof (EF) is 125°F (52°C)

All others: 32°F to 104°F (0°C to 40°C)

Refer to *Engineering Section* for details.

Approvals

CSA certified. UL listed General Purpose Valves.

Meets applicable CE directives.

Installation

For optimum life, the valve should be installed with the solenoid positioned upright and vertical.

Refer to *Engineering Section* for details.

Specifications (English units)

Pipe Size (ins.)	Orifice Size (ins.)	Cv Flow Factor	Operating Pressure Differential (psi)		Max. Fluid Temp. °F	Catalog Number			Watt Rating/Class of Coil Insulation	
			Min.	Max. AC (DC)		Brass	Stainless Steel	Aluminum		AC (DC)
				Air-Inert Gas						
2/2 VALVES (5 MILLION CYCLE CAPABILITY)										
NORMALLY CLOSED (Closed when de-energized)										
3/8	5/8	3	5	125	140	8210G001Q	-	-	15.1/F	
1/2	5/8	4	5	125	140	8210G002Q	-	-	15.1/F	
3/4	3/4	4.5	5	125	140	8210G009Q	-	-	15.1/F	
1	1 5/8	13	1	20	140	-	-	8215G095Q	15.1/F	
1 1/4	1 5/8	15	1	20	140	-	-	8215G096Q	15.1/F	
1 1/2	1 5/8	20	1	20	140	-	-	8215G097Q	15.1/F	
2	2 3/32	34	1	20	140	-	-	8215G098Q	15.1/F	
NORMALLY OPEN (Open when de-energized)										
3/8	5/8	3	5	125	140	8210G011Q	-	-	15.1/F	
1/2	5/8	4	5	125	140	8210G012Q	-	-	15.1/F	
3/4	3/4	4.5	5	125	140	8210G013Q	-	-	15.1/F	
1	1 5/8	13	1	20	140	-	-	8215G099Q	15.1/F	
1 1/4	1 5/8	15	1	20	140	-	-	8215G100Q	15.1/F	
1 1/2	1 5/8	20	1	20	140	-	-	8215G101Q	15.1/F	
2	2 3/32	34	1	20	140	-	-	8215G102Q	15.1/F	
2/2 VALVES (20 MILLION CYCLE CAPABILITY)										
NORMALLY CLOSED (Closed when de-energized)										
1/8	1/8	0.35	0	125 (60)	140	8262H077Q	8262H179Q	-	15.1/F (11.6)	
1/4	3/32	0.21	0	150 (110)	140	8262H108Q	8262H182Q	-	15.1/F (11.6)	
1/4	1/8	0.35	0	125 (60)	140	8262H232Q	8262H184Q	-	15.1/F (11.6)	
1/4	5/32	0.52	0	50 (40)	140	8262H202Q	8262H220Q	-	15.1/F (11.6)	
1/4	7/32	0.73	0	50 (20)	140	8262H208Q	8262H226Q	-	15.1/F (11.6)	
1/4	9/32	0.88	0	20 (13)	140	8262H210Q	8262H189Q	-	15.1/F (11.6)	
3/8	1/8	0.35	0	125 (60)	140	8263H232Q	8263H190Q	-	15.1/F (11.6)	
3/8	5/32	0.52	0	50 (40)	140	8263H200Q	8263H331Q	-	15.1/F (11.6)	
3/8	7/32	0.73	0	50 (20)	140	8263H124Q	8263H195Q	-	15.1/F (11.6)	
3/8	9/32	0.88	0	20 (13)	140	8263H125Q	8263H197Q	-	15.1/F (11.6)	
NORMALLY OPEN (Open when de-energized)										
1/8	1/16	.09	0	125	140	8262G091Q	-	-	15.1/F	
1/4	1/16	.09	0	125	140	8262G032Q	-	-	15.1/F	
3/2 VALVES (5 MILLION CYCLE CAPABILITY)										
NORMALLY CLOSED (Closed when de-energized)										
3/8	5/8	3	10	125	140	8316G014Q ②	-	-	15.1/F	
1/2	5/8	4	10	125	140	8316G024Q ②	-	-	15.1/F	
NORMALLY OPEN (Open when de-energized)										
3/8	5/8	3	10	125	140	8316G016Q ②	-	-	15.1/F	
1/2	5/8	4	10	125	140	8316G026Q ②	-	-	15.1/F	
3/2 VALVES (20 MILLION CYCLE CAPABILITY)										
UNIVERSAL OPERATION (Pressure at any port)										
1/8	1/16	.09	0	70	140	8320G001Q	-	-	15.1/F	
1/4	1/16	.09	0	70	140	8320G172Q	-	-	15.1/F	
1/4	3/32	.15	0	40	140	8320G174Q	-	-	15.1/F	
NORMALLY CLOSED (Closed when de-energized)										
1/8	1/16	.09	0	125	140	8320G013Q	-	-	15.1/F	
1/4	1/16	.09	0	125	140	8320G182Q	-	-	15.1/F	
1/4	1/8	.31	0	35	140	8320G186Q	-	-	15.1/F	
NORMALLY OPEN (Open when de-energized)										
1/8	1/16	.09	0	125	140	8320G027Q	-	-	15.1/F	
1/4	1/16	.09	0	125	140	8320G192Q	-	-	15.1/F	
1/4	1/8	.31	0	35	140	8320G196Q	-	-	15.1/F	
4/2 VALVES (5 MILLION CYCLE CAPABILITY)										
SINGLE SOLENOID										
1/4	1/4	.53	10	125	140	8344G070Q ②	-	-	15.1/F	
3/8	1/4	.53	10	125	140	8344G001Q ②	-	-	15.1/F	
1/2	3/8	1.3	10	125	140	8344G074Q ②	-	-	15.1/F	
4/2 VALVES (20 MILLION CYCLE CAPABILITY)										
SINGLE SOLENOID										
1/4	1/16	①	10	100	140	8345G002Q ②	-	-	15.1/F	

① Inlet Cv is 0.036; exhaust Cv is 0.092. ② **IMPORTANT:** A Minimum Operating Pressure Differential must be maintained between the pressure and exhaust ports. Supply and exhaust piping must be full area, unrestricted. ASCO flow controls and other similar components must be installed in the cylinder lines only.

SPECIAL SERVICE VALVES

Specifications (Metric units)

Pipe Size (ins.)	Orifice Size (mm)	Kv Flow Factor (m ³ /h)	Operating Pressure Differential (bar)		Max. Fluid Temp. °C	Catalog Number			Watt Rating/Class of Coil Insulation AC (DC)	
			Min.	Max. AC Air-Inert Gas		Brass	Stainless Steel	Aluminum		
2/2 VALVES (5 MILLION CYCLE CAPABILITY)										
NORMALLY CLOSED (Closed when de-energized)										
3/8	16	2.57	0.3	8.6	60	8210G001Q	-	-	15.1/F	
1/2	16	3.43	0.3	8.6	60	8210G002Q	-	-	15.1/F	
3/4	19	3.86	0.3	8.6	60	8210G009Q	-	-	15.1/F	
1	41	11.14	0.1	1.4	60	-	-	8215G095Q	15.1/F	
1 1/4	41	12.86	0.1	1.4	60	-	-	8215G096Q	15.1/F	
1 1/2	41	17.14	0.1	1.4	60	-	-	8215G097Q	15.1/F	
2	53	29.14	0.1	1.4	60	-	-	8215G098Q	15.1/F	
NORMALLY OPEN (Open when de-energized)										
3/8	16	2.57	0.3	8.6	60	8210G011Q	-	-	15.1/F	
1/2	16	3.43	0.3	8.6	60	8210G012Q	-	-	15.1/F	
3/4	19	3.86	0.3	8.6	60	8210G013Q	-	-	15.1/F	
1	41	11.14	0.1	1.4	60	-	-	8215G099Q	15.1/F	
1 1/4	41	12.86	0.1	1.4	60	-	-	8215G100Q	15.1/F	
1 1/2	41	17.14	0.1	1.4	60	-	-	8215G101Q	15.1/F	
2	53	29.14	0.1	1.4	60	-	-	8215G102Q	15.1/F	
2/2 VALVES (20 MILLION CYCLE CAPABILITY)										
NORMALLY CLOSED (Closed when de-energized)										
1/8	1/8	0.30	0	8.6 (4.1)	60	8262H077Q	8262H179Q	-	15.1/F (11.6)	
1/4	3/32	0.18	0	10.3 (7.6)	60	8262H108Q	8262H182Q	-	15.1/F (11.6)	
1/4	1/8	0.30	0	8.6 (4.1)	60	8262H232Q	8262H184Q	-	15.1/F (11.6)	
1/4	5/32	0.45	0	3.4 (2.8)	60	8262H202Q	8262H220Q	-	15.1/F (11.6)	
1/4	7/32	0.63	0	3.4 (1.4)	60	8262H208Q	8262H226Q	-	15.1/F (11.6)	
1/4	9/32	0.76	0	1.4 (0.9)	60	8262H210Q	8262H189Q	-	15.1/F (11.6)	
3/8	1/8	0.30	0	8.6 (4.1)	60	8263H232Q	8263H190Q	-	15.1/F (11.6)	
3/8	5/32	0.45	0	3.4 (2.8)	60	8263H200Q	8263H331Q	-	15.1/F (11.6)	
3/8	7/32	0.63	0	3.4 (1.4)	60	8263H124Q	8263H195Q	-	15.1/F (11.6)	
3/8	9/32	0.76	0	1.4 (0.9)	60	8263H125Q	8263H197Q	-	15.1/F (11.6)	
NORMALLY OPEN (Open when de-energized)										
1/8	2	.08	0.0	8.6	60	8262G091Q	-	-	15.1/F	
1/4	2	.08	0.0	8.6	60	8262G032Q	-	-	15.1/F	
3/2 VALVES (5 MILLION CYCLE CAPABILITY)										
NORMALLY CLOSED (Closed when de-energized)										
3/8	16	2.57	0.7	8.6	60	8316G014Q ②	-	-	15.1/F	
1/2	16	3.43	0.7	8.6	60	8316G024Q ②	-	-	15.1/F	
NORMALLY OPEN (Open when de-energized)										
3/8	16	2.57	0.7	8.6	60	8316G016Q ②	-	-	15.1/F	
1/2	16	3.43	0.7	8.6	60	8316G026Q ②	-	-	15.1/F	
3/2 VALVES (20 MILLION CYCLE CAPABILITY)										
UNIVERSAL OPERATION (Pressure at any port)										
1/8	2	.08	0.0	4.8	60	8320G001Q	-	-	15.1/F	
1/4	2	.08	0.0	4.8	60	8320G172Q	-	-	15.1/F	
1/4	2	.13	0.0	2.8	60	8320G174Q	-	-	15.1/F	
NORMALLY CLOSED (Closed when de-energized)										
1/8	2	.08	0.0	8.6	60	8320G013Q	-	-	15.1/F	
1/4	2	.08	0.0	8.6	60	8320G182Q	-	-	15.1/F	
1/4	3	.27	0.0	2.4	60	8320G186Q	-	-	15.1/F	
NORMALLY OPEN (Open when de-energized)										
1/8	2	.08	0.0	8.6	60	8320G027Q	-	-	15.1/F	
1/4	2	.08	0.0	8.6	60	8320G192Q	-	-	15.1/F	
1/4	3	.27	0.0	2.4	60	8320G196Q	-	-	15.1/F	
4/2 VALVES (5 MILLION CYCLE CAPABILITY)										
SINGLE SOLENOID										
1/4	6	.45	0.7	8.6	60	8344G070Q ②	-	-	15.1/F	
3/8	6	.45	0.7	8.6	60	8344G001Q ②	-	-	15.1/F	
1/2	10	1.11	0.7	8.6	60	8344G074Q ②	-	-	15.1/F	
4/2 VALVES (20 MILLION CYCLE CAPABILITY)										
SINGLE SOLENOID										
1/4	2	①	0.7	6.9	60	8345G002Q ②	-	-	15.1/F	

① Inlet Kv is 0.031; exhaust Kv is 0.079. ② **IMPORTANT:** A Minimum Operating Pressure Differential must be maintained between the pressure and exhaust ports. Supply and exhaust piping must be full area, unrestricted. ASCO flow controls and other similar components must be installed in the cylinder lines only.

Dimensions inches (mm)

Note: *Please see General Service Section for applicable 2-way, 3-way, and 4-way valve dimensions.*