

### Bleed-orifice or Bleed Hole

Small orifice or channel, most often located in the diaphragm or piston of pilot-operated valves, to allow the inlet flow to pressurize the top side of the diaphragm or piston.

### Bonnet

Screwed plug or bolted cover on the valve body, on which the core tube with inner parts is fitted.

### Coil

Electrical part of the valve consisting of a spool wound with insulated copper wire which creates a magnetic flux when energized.

### Core

The soft-magnetic stainless steel part of the solenoid which is moved by magnetic forces (flux generated by the coil).

### Core Spring

Spring which returns the core to the original position when the coil is de-energized.

### Core Tube

Stainless steel tube, closed at one end, which isolates the media in the valve from the external solenoid parts.

### Disc, Valve Disc

Sealing material on the core or disc-holder, which shuts off the seat orifice.

### Disc-holder

Valve part, actuated by the core, in which a sealing disc is inserted.

### Main Orifice

Principle passage between inlet and outlet of the valve.

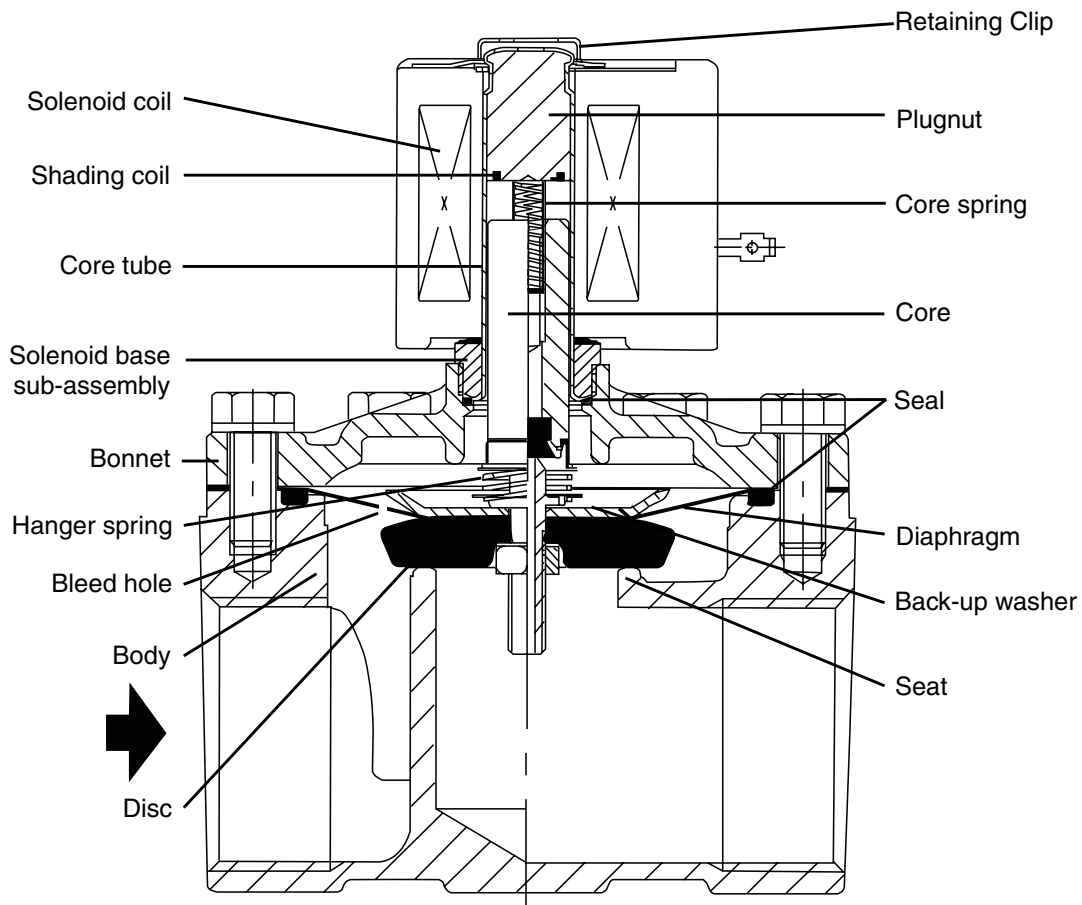

## Maximum Ambient Temperature

The nominal maximum ambient temperatures listed are based primarily on test conditions in determining safe limits for coil insulation. They are energized conditions, with maximum fluid temperatures existing in the valve.

## Maximum Operating Pressure Differential (M.O.P.D.)

The maximum operating pressure differential refers to the difference in pressure between the inlet and the outlet sides of the valve, against which the solenoid can safely operate. If the pressure at the valve outlet is not known, the conservative approach is to regard the supply pressure as the M.O.P.D.

## Minimum Ambient Temperature

The nominal limitation of 32°F (0°C) is advisable for any valve that might contain moisture (water vapor). Where freezing water is not a factor, minimum ambients as low as -4°F (-20°C) can be tolerated. In addition, special constructions are available for ambient temperatures down to -40°F (-40°C). *Consult your local ASCO sales office with your specific needs.*

## Minimum Operating Pressure Differential

The minimum operating pressure differential is that which is required to open the valve and keep it open. For 2-way valves with floating piston or diaphragm, the valve will start to close below the minimum differential pressure.

**Note:** Direct acting hung diaphragm or hung piston valves do not require a minimum operating pressure.

For 3- and 4-way pilot valves, the minimum operating pressure is measured between the pressure and exhaust ports and must be maintained throughout the operation cycle to ensure complete transfer from one position to the other.

## Pilot Orifice

Orifice located in the center of a diaphragm or piston, or in the pilot area of pilot-operated valves, opened or closed by the core.

## Plugnut

Stationary soft magnetic stainless part, pressed in the closed end of the core tube, installed to improve the magnetic flux of the solenoid coil when energized.

## Response Time

This is the time lapse after energizing (or de-energizing) a solenoid valve until the outlet pressure reaches a specific percentage of its maximum steady value, the outlet being connected to a circuit having specified flow parameters. Response time depends on five factors:

1. Electrical supply: AC or DC.
2. Fluid handled by the valve, viscosity and pressure level.
3. Type of operation: direct or pilot operated.
4. Size of the moving parts of the valve mechanism.
5. Circuit in which the time is measured.

## Seating or Valve Seat

Geometry within valve that creates internal seal.

## Shading Coil

Ring (typically copper) inserted in the core-side surface of the plugnut to limit core vibration in AC-powered solenoids.

## Solenoid Base Sub-assembly

Assembly of core tube, plugnut, and bonnet.

## Solenoid

Electromagnetic part of a valve, comprised of a coil, core tube, core, and enclosure.

## Solenoid Construction

Internal parts in contact with the fluid are made of non-magnetic 300 and magnetic 400 Series stainless steel. In AC constructions, the shading coil is copper, except for valves in which silver is used. Other materials are available, when required. Generally, no shading coil is used in DC valves. The core tube in ASCO valves is 300 Series stainless steel and formed by deep drawing.

## Solenoid Enclosure

Housing around the coil for electrical and mechanical protection, as well as protection against environmental hazards.

## Valve Body

Main part of the valve, in which ports and main seats are located.

The function of a valve is shown by two figures. The first shows the number of ports, the second shows the number of valve positions (pilot ports do not count).

Example: 4/2 = 4 ports, 2 positions (open or closed).

The symbol for a valve has the same number of squares as the valve has positions.

Example: 2 positions =

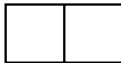

Arrows in the squares show the flow direction of the fluid.

Examples: One flow path =



Two flow paths =



T-lines in the squares show the number of closed ports.

Example:



Two flow paths and one closed port.

Example:



In this catalog, the vast majority of valves listed have only two positions, in which the right-hand square shows the valve unoperated and the left-hand square shows the valve operated.

### Normally Open (NO)

Example:

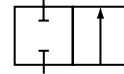

### Normally Closed (NC)

Example:

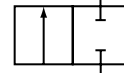

Normally, the pipework is shown connected to the square representing the valve unoperated.

### Symbols Showing Connections to Ports:

Exhaust that cannot be piped:



Exhaust that can be piped:



Connected to pressure source:



The methods of controlling the valve are shown as an addition to the squares. The left-hand side control shows the pilot (i.e. solenoid) and the right-hand side control shows the return pilot method (i.e. spring).

Example:

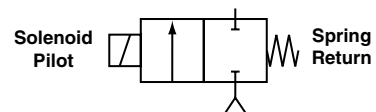

## ISO Symbols for Valves Included in This Catalog:

Ports/Positions	Function	Pilot	Return Pilot	Symbol
2/2	NC	Solenoid	Spring	
2/2	NC	Solenoid/Ext. Pressure	Spring	
2/2	NC	Solenoid/Int. Pressure	Spring	
2/2	NO	Solenoid	Spring	
2/2	NC	Ext. Pressure	Spring	
2/2	NO	Ext. Pressure	Spring	
3/2	NC	Solenoid	Spring	
3/2	NC	Solenoid/Int. Pressure	Spring	
3/2	NO	Solenoid	Spring	
3/2	NO	Solenoid/Ext. Pressure	Spring	
3/2	NO	Solenoid/Int. Pressure	Spring	
3/2	U	Solenoid	Spring	
3/2	NC	Ext. Pressure	Spring	
3/2	NO	Ext. Pressure	Spring	
3/2 - (4/2)	NC	Solenoid/Int. Pressure	Spring	
4/2	-	Solenoid	Spring	
4/2	-	Solenoid/Int. Pressure	Spring	