

The Series 190 & 330 are 2-way, normally closed isolation valves constructed with TFE materials, which makes them virtually impervious to chemical attack. The Series 190 is a single valve while the Series 330 offers the same valve in a 2, 3, or 4 position manifold configuration for use in chromatography, solvent selection, and process sampling.

- PTFE diaphragm shields the internal components of the solenoid from the media to handle the most aggressive fluids
- Compact size saves valuable space in equipment
- Low power consumption

### Construction

Valve Parts in Contact with Fluids	
Body	PTFE
Seat	CTFE
Diaphragm	PTFE

### Electrical

Standard Voltages	12, 24 VDC+ 10%, -5%
Power Consumption	2.9 - 3.8 Watts (12 watts for latching version)
Duty Cycle Rating	Continuous (Intermittent for latching version)
Coil Insulation	356°F (180°C)
Electrical Connection	26 gage lead wire

### Valve

Response Time	~5 ms at rated voltage (2 watt coil)
Internal Volume	20 µL from port 1 to seat (not including port) 52 µL from port 2 to seat (not including port)
Options	<ul style="list-style-type: none"> <li>• Magnetic Latching</li> <li>• Single valve or 2, 3, and 4 position manifolds</li> </ul>
Vacuum Rating	29" Hg

### Alternative Constructions

Many alternative constructions are available and include a variety of voltages, electrical connectors, and materials of construction. ASCO Scientific can also custom design a valve for your specific application.

Contact your local ASCO sales office for more information.

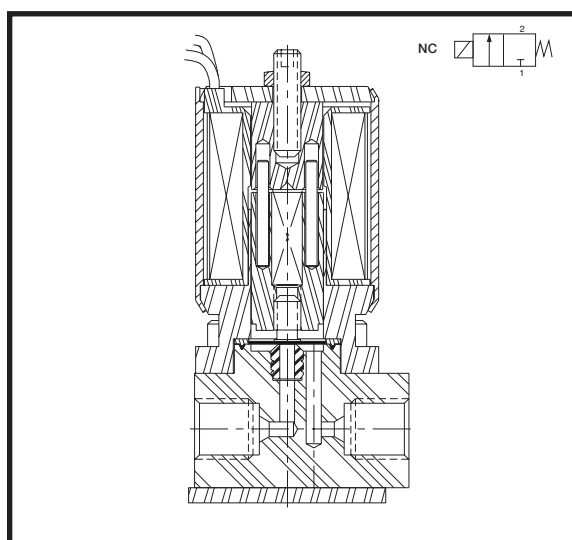
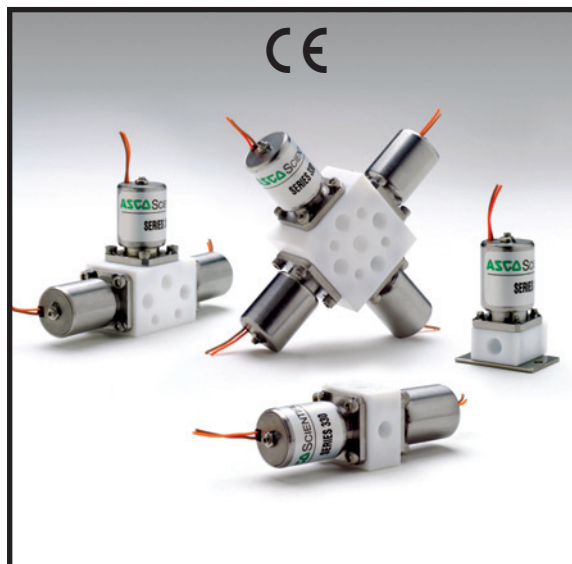

### Temperature Range:

Ambient & Media:  
32°F to 77°F (0°C to 25°C) continuous duty  
up to 104°F (40°C) intermittent duty

### Approvals:

Meets applicable CE directives

## Specifications

Ports	Orifice Size (ins.)	Cv Flow Factor	Maximum Pressure (psi)	Catalog Number	No. of Solenoids	Watt Rating @ 20°C	Weight (oz.)
<b>2-WAY NORMALLY CLOSED (Closed when de-energized)</b>							
1/4 - 28 UNF Flat Bottom	0.062	0.03	30	1902xxS30	1	2.9 (12VDC), 3.8 (24VDC)	2.0
1/4 - 28 UNF Flat Bottom	0.062	0.03	30	3302xxS302	2	2.9 (12VDC), 3.8 (24VDC)	4.1
1/4 - 28 UNF Flat Bottom	0.062	0.03	30	3302xxS303	3	2.9 (12VDC), 3.8 (24VDC)	6.5
1/4 - 28 UNF Flat Bottom	0.062	0.03	30	3302xxS304	4	2.9 (12VDC), 3.8 (24VDC)	9.7
<b>2-WAY LATCHING</b>							
1/4 - 28 UNF Flat Bottom	0.062	0.03	30	1902xxL30	1	12*	2.0
1/4 - 28 UNF Flat Bottom	0.062	0.03	30	3302xxL302	2	12*	4.1
1/4 - 28 UNF Flat Bottom	0.062	0.03	30	3302xxL303	3	12*	6.5
1/4 - 28 UNF Flat Bottom	0.062	0.03	30	3302xxL304	4	12*	9.7

### Notes

"xx" Denotes place in catalog number for voltage

\* Latching valves are designed for intermittent duty only. Wattage rating applies to 20 – 30 ms duration required to actuate valve. Once switched no additional power is required to hold the valve in its position.

## Catalog Number Description and Options

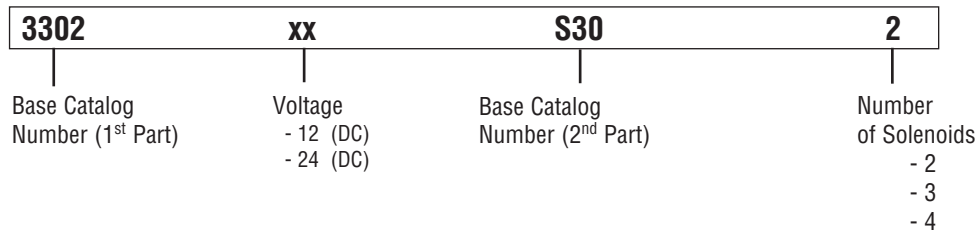

## To Construct Catalog Number

- Select base catalog number
- Insert voltage into the 5<sup>th</sup> and 6<sup>th</sup> digits denoted by "xx"
- Add number of solenoids (330 series only)

## Examples

190212S30 = 2-way normally closed valve with 1/4 - 28 UNF, flat bottom ports and 12 VDC coil rated at 2.9 Watts

190224L30 = 2-way latching valve with 1/4 - 28 UNF, flat bottom ports and 24 vdc latching coil

330224S303 = 3, 2-way normally closed valves mounted on a manifold with 1/4 - 28 UNF, flat bottom ports and 24 vdc coil rated at 3.8 Watts

Dimensions Series 190: Inches [mm]

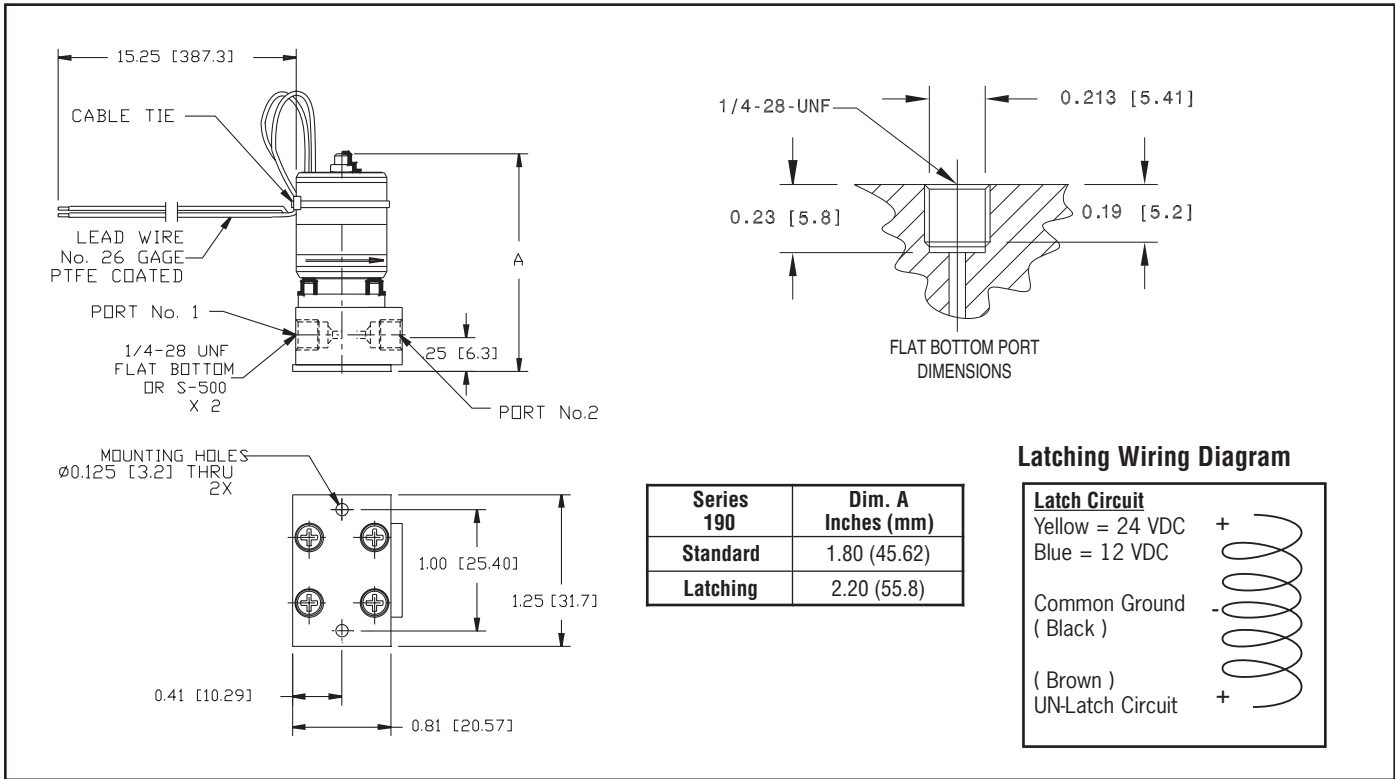

Dimensions Series 330 2 Position Valve Manifold: Inches [mm]

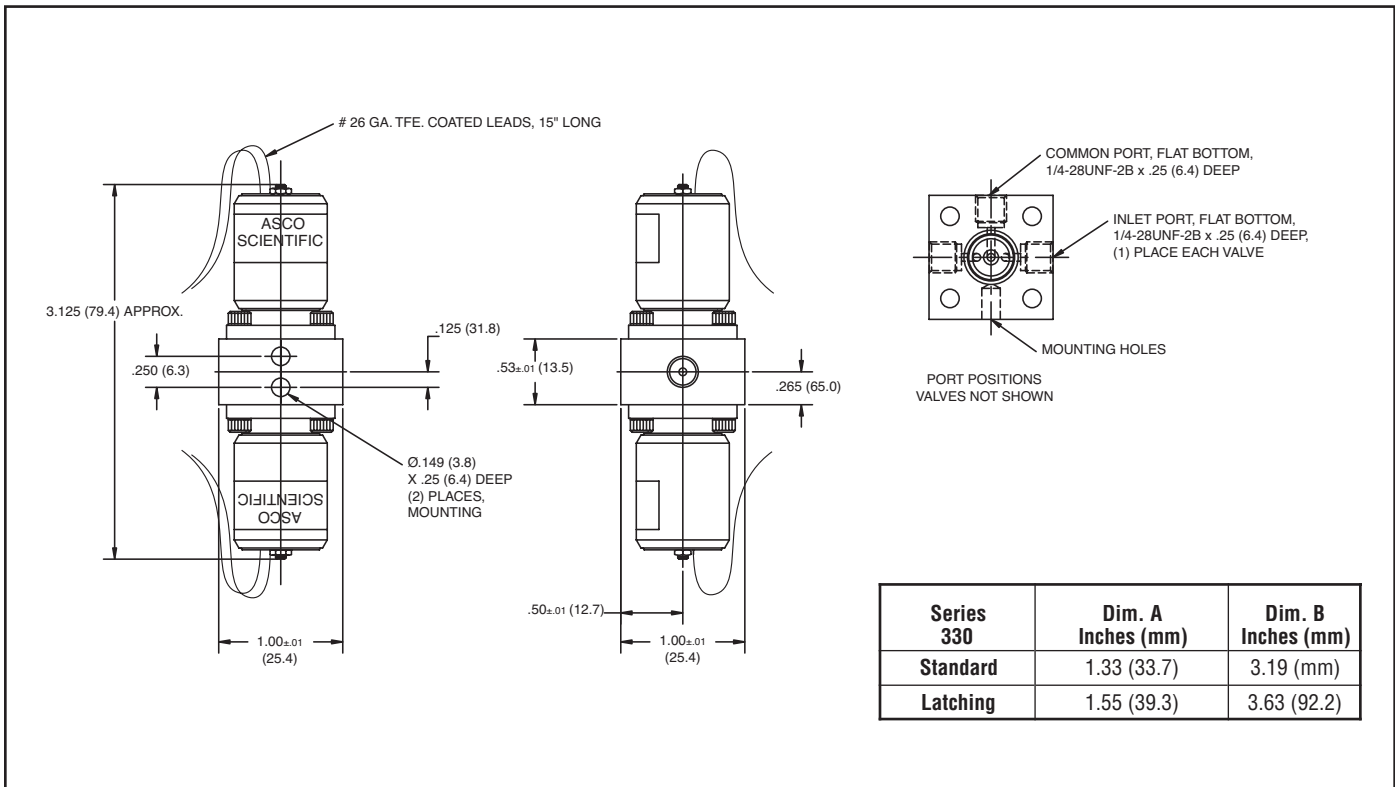

Dimensions Series 330 3 Position Valve Manifold: Inches [mm]

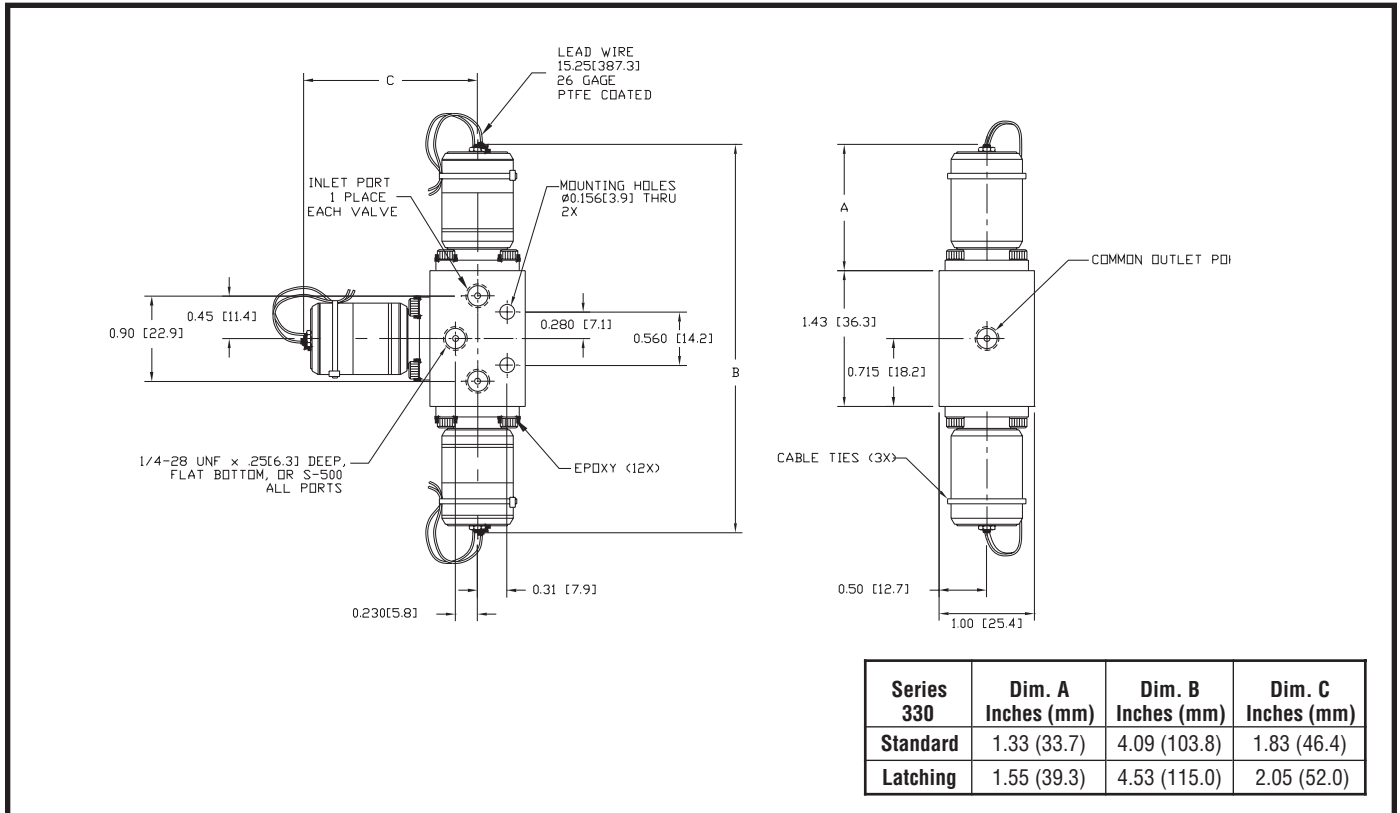

Dimensions Series 330 4 Position Valve Manifold: Inches [mm]

